

DATA SHEET

PCD8544

**48 × 84 pixels matrix LCD
controller/driver**

Product specification
File under Integrated Circuits, IC17

1999 Apr 12

48 × 84 pixels matrix LCD controller/driver**PCD8544**

CONTENTS			
1	FEATURES	8	INSTRUCTIONS
2	GENERAL DESCRIPTION	8.1	Initialization
3	APPLICATIONS	8.2	Reset function
4	ORDERING INFORMATION	8.3	Function set
5	BLOCK DIAGRAM	8.3.1	Bit PD
6	PINNING	8.3.2	Bit V
6.1	Pin functions	8.3.3	Bit H
6.1.1	R0 to R47 row driver outputs	8.4	Display control
6.1.2	C0 to C83 column driver outputs	8.4.1	Bits D and E
6.1.3	V _{SS1} , V _{SS2} : negative power supply rails	8.5	Set Y address of RAM
6.1.4	V _{DD1} , V _{DD2} : positive power supply rails	8.6	Set X address of RAM
6.1.5	V _{LCD1} , V _{LCD2} : LCD power supply	8.7	Temperature control
6.1.6	T1, T2, T3 and T4: test pads	8.8	Bias value
6.1.7	SDIN: serial data line	8.9	Set V _{OP} value
6.1.8	SCLK: serial clock line	9	LIMITING VALUES
6.1.9	D/C: mode select	10	HANDLING
6.1.10	SCE: chip enable	11	DC CHARACTERISTICS
6.1.11	OSC: oscillator	12	AC CHARACTERISTICS
6.1.12	RES: reset	12.1	Serial interface
7	FUNCTIONAL DESCRIPTION	12.2	Reset
7.1	Oscillator	13	APPLICATION INFORMATION
7.2	Address Counter (AC)	14	BONDING PAD LOCATIONS
7.3	Display Data RAM (DDRAM)	14.1	Bonding pad information
7.4	Timing generator	14.2	Bonding pad location
7.5	Display address counter	15	TRAY INFORMATION
7.6	LCD row and column drivers	16	DEFINITIONS
7.7	Addressing	17	LIFE SUPPORT APPLICATIONS
7.7.1	Data structure		
7.8	Temperature compensation		

48 × 84 pixels matrix LCD controller/driver**PCD8544****1 FEATURES**

- Single chip LCD controller/driver
- 48 row, 84 column outputs
- Display data RAM 48 × 84 bits
- On-chip:
 - Generation of LCD supply voltage (external supply also possible)
 - Generation of intermediate LCD bias voltages
 - Oscillator requires no external components (external clock also possible).
- External $\overline{\text{RES}}$ (reset) input pin
- Serial interface maximum 4.0 Mbits/s
- CMOS compatible inputs
- Mux rate: 48
- Logic supply voltage range V_{DD} to V_{SS} : 2.7 to 3.3 V
- Display supply voltage range V_{LCD} to V_{SS}
 - 6.0 to 8.5 V with LCD voltage internally generated (voltage generator enabled)
 - 6.0 to 9.0 V with LCD voltage externally supplied (voltage generator switched-off).
- Low power consumption, suitable for battery operated systems
- Temperature compensation of V_{LCD}
- Temperature range: –25 to +70 °C.

2 GENERAL DESCRIPTION

The PCD8544 is a low power CMOS LCD controller/driver, designed to drive a graphic display of 48 rows and 84 columns. All necessary functions for the display are provided in a single chip, including on-chip generation of LCD supply and bias voltages, resulting in a minimum of external components and low power consumption.

The PCD8544 interfaces to microcontrollers through a serial bus interface.

The PCD8544 is manufactured in n-well CMOS technology.

3 APPLICATIONS

- Telecommunications equipment.

4 ORDERING INFORMATION

TYPE NUMBER	PACKAGE		
	NAME	DESCRIPTION	VERSION
PCD8544U	–	chip with bumps in tray; 168 bonding pads + 4 dummy pads	–

48 × 84 pixels matrix LCD controller/driver

PCD8544

5 BLOCK DIAGRAM

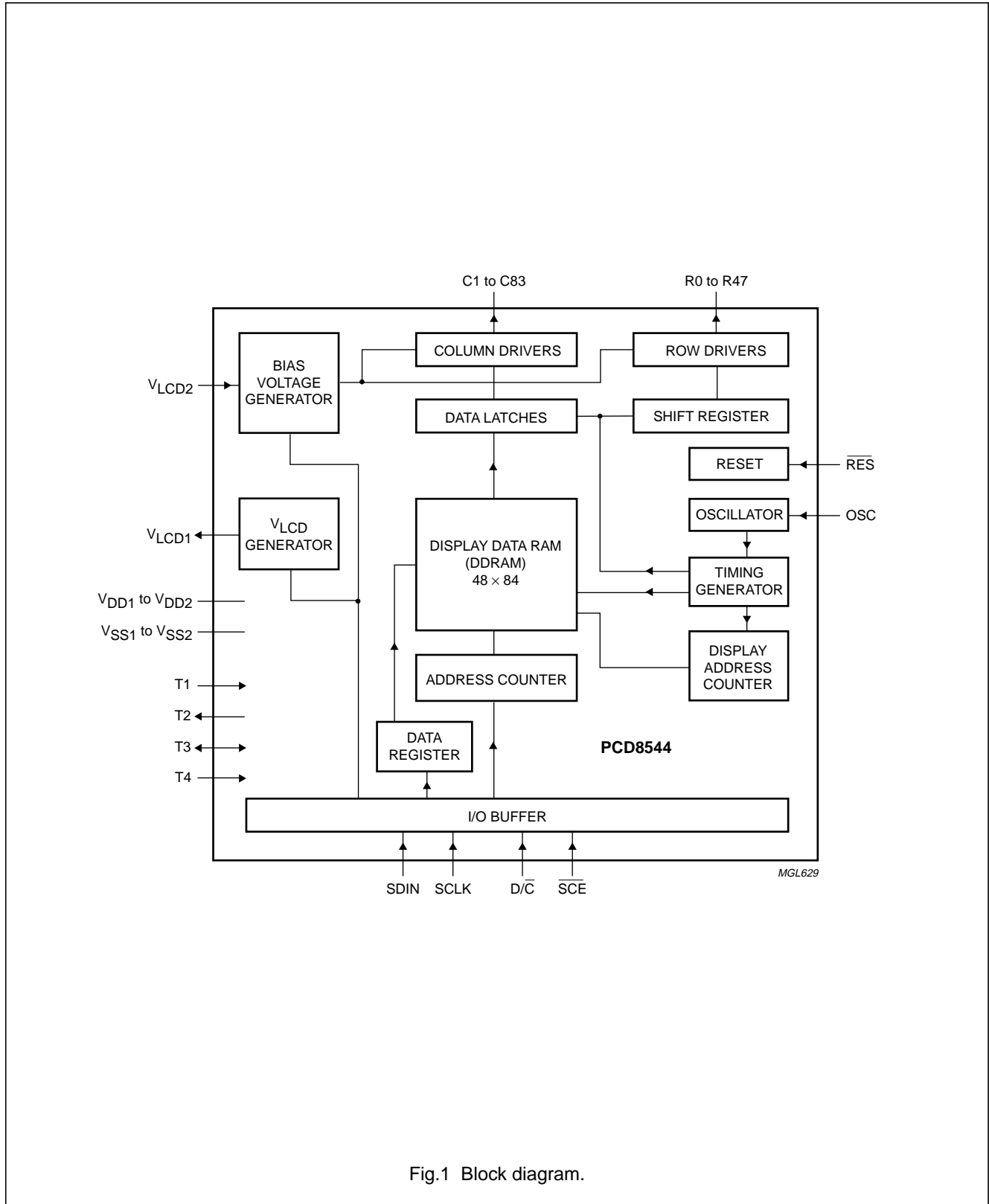

Fig.1 Block diagram.

48 × 84 pixels matrix LCD controller/driver

PCD8544

6 PINNING

SYMBOL	DESCRIPTION
R0 to R47	LCD row driver outputs
C0 to C83	LCD column driver outputs
V _{SS1} , V _{SS2}	ground
V _{DD1} , V _{DD2}	supply voltage
V _{LCD1} , V _{LCD2}	LCD supply voltage
T1	test 1 input
T2	test 2 output
T3	test 3 input/output
T4	test 4 input
SDIN	serial data input
SCLK	serial clock input
D/ \overline{C}	data/command
\overline{SCE}	chip enable
OSC	oscillator
\overline{RES}	external reset input
dummy1, 2, 3, 4	not connected

Note

1. For further details, see Fig.18 and Table 7.

6.1 Pin functions

6.1.1 R0 TO R47 ROW DRIVER OUTPUTS

These pads output the row signals.

6.1.2 C0 TO C83 COLUMN DRIVER OUTPUTS

These pads output the column signals.

6.1.3 V_{SS1}, V_{SS2}: NEGATIVE POWER SUPPLY RAILS

Supply rails V_{SS1} and V_{SS2} must be connected together.

6.1.4 V_{DD1}, V_{DD2}: POSITIVE POWER SUPPLY RAILS

Supply rails V_{DD1} and V_{DD2} must be connected together.

6.1.5 V_{LCD1}, V_{LCD2}: LCD POWER SUPPLY

Positive power supply for the liquid crystal display. Supply rails V_{LCD1} and V_{LCD2} must be connected together.

6.1.6 T1, T2, T3 AND T4: TEST PADS

T1, T3 and T4 must be connected to V_{SS}, T2 is to be left open. Not accessible to user.

6.1.7 SDIN: SERIAL DATA LINE

Input for the data line.

6.1.8 SCLK: SERIAL CLOCK LINE

Input for the clock signal: 0.0 to 4.0 Mbits/s.

6.1.9 D/ \overline{C} : MODE SELECT

Input to select either command/address or data input.

6.1.10 \overline{SCE} : CHIP ENABLE

The enable pin allows data to be clocked in. The signal is active LOW.

6.1.11 OSC: OSCILLATOR

When the on-chip oscillator is used, this input must be connected to V_{DD}. An external clock signal, if used, is connected to this input. If the oscillator and external clock are both inhibited by connecting the OSC pin to V_{SS}, the display is not clocked and may be left in a DC state. To avoid this, the chip should always be put into Power-down mode before stopping the clock.

6.1.12 \overline{RES} : RESET

This signal will reset the device and must be applied to properly initialize the chip. The signal is active LOW.

48 × 84 pixels matrix LCD controller/driver**PCD8544**

7 FUNCTIONAL DESCRIPTION**7.1 Oscillator**

The on-chip oscillator provides the clock signal for the display system. No external components are required and the OSC input must be connected to V_{DD} . An external clock signal, if used, is connected to this input.

7.2 Address Counter (AC)

The address counter assigns addresses to the display data RAM for writing. The X-address X_6 to X_0 and the Y-address Y_2 to Y_0 are set separately. After a write operation, the address counter is automatically incremented by 1, according to the V flag.

7.3 Display Data RAM (DDRAM)

The DDRAM is a 48×84 bit static RAM which stores the display data. The RAM is divided into six banks of 84 bytes ($6 \times 8 \times 84$ bits). During RAM access, data is transferred to the RAM through the serial interface. There is a direct correspondence between the X-address and the column output number.

7.4 Timing generator

The timing generator produces the various signals required to drive the internal circuits. Internal chip operation is not affected by operations on the data buses.

7.5 Display address counter

The display is generated by continuously shifting rows of RAM data to the dot matrix LCD through the column outputs. The display status (all dots on/off and normal/inverse video) is set by bits E and D in the 'display control' command.

7.6 LCD row and column drivers

The PCD8544 contains 48 row and 84 column drivers, which connect the appropriate LCD bias voltages in sequence to the display in accordance with the data to be displayed. Figure 2 shows typical waveforms. Unused outputs should be left unconnected.

48 × 84 pixels matrix LCD controller/driver

PCD8544

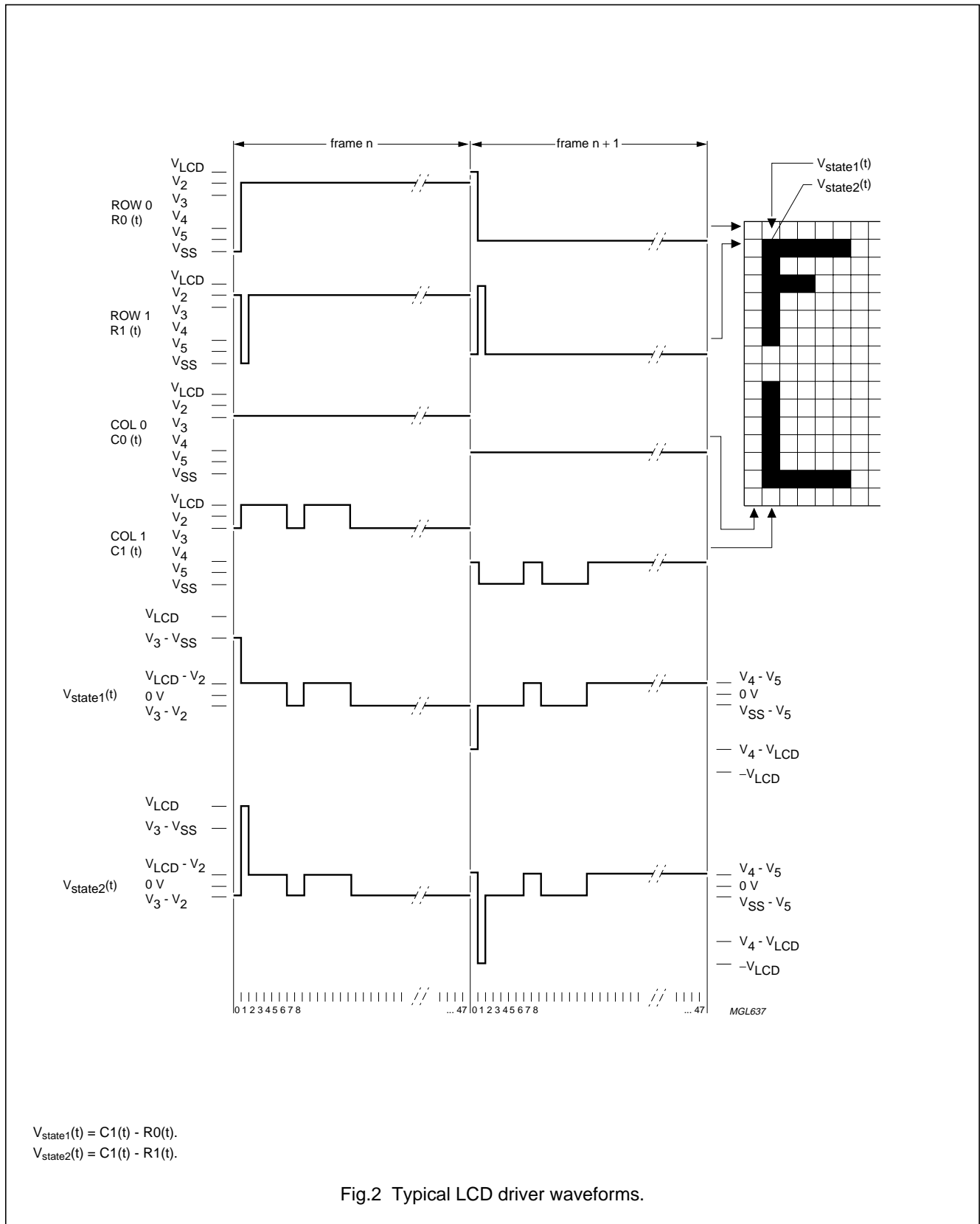

Fig.2 Typical LCD driver waveforms.

48 × 84 pixels matrix LCD controller/driver

PCD8544

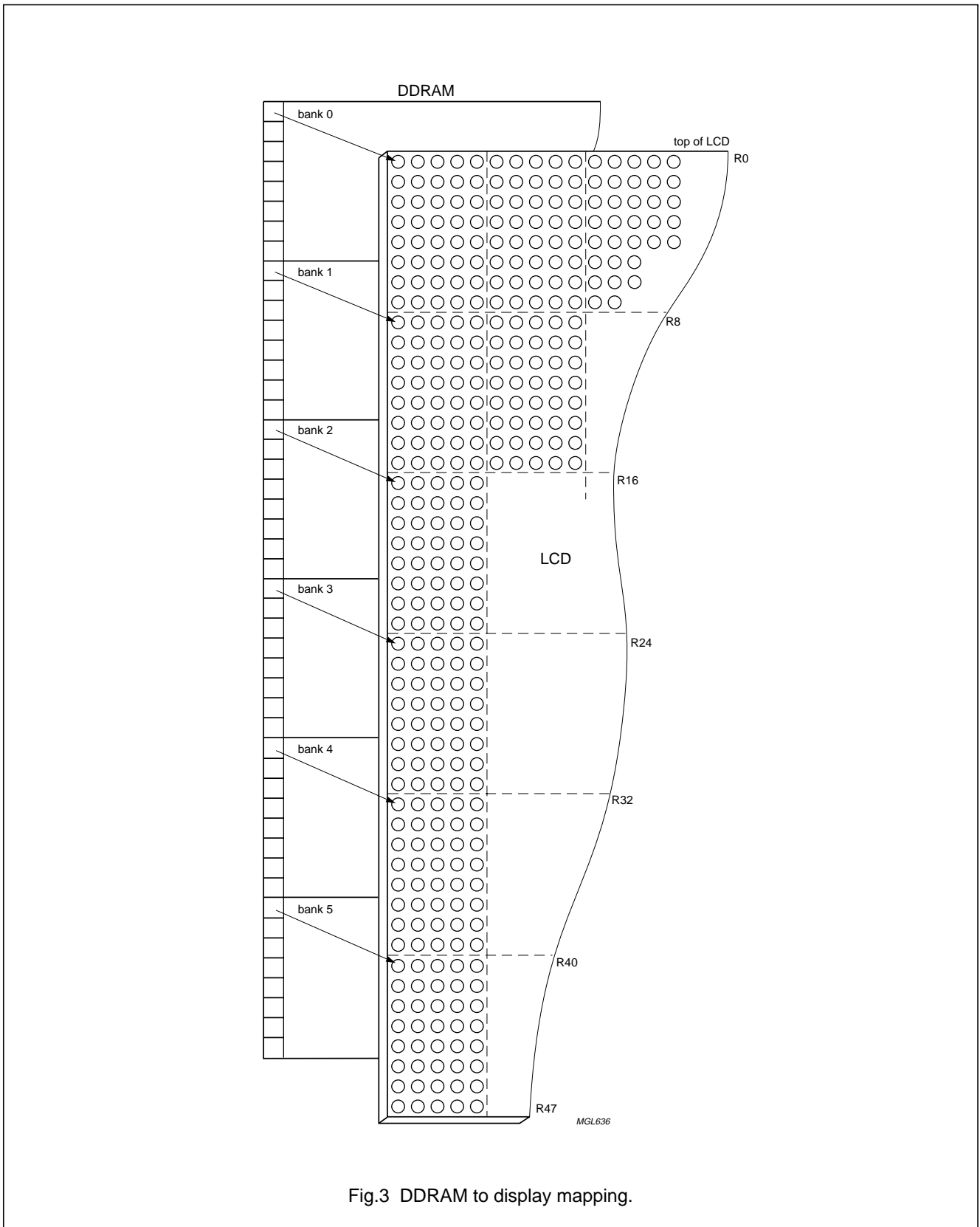

Fig.3 DDRAM to display mapping.

48 × 84 pixels matrix LCD controller/driver

PCD8544

7.7 Addressing

Data is downloaded in bytes into the 48 by 84 bits RAM data display matrix of PCD8544, as indicated in Figs. 3, 4, 5 and 6. The columns are addressed by the address pointer. The address ranges are: X 0 to 83 (1010011), Y 0 to 5 (101). Addresses outside these ranges are not allowed. In the vertical addressing mode (V = 1), the Y address increments after each byte (see

Fig.5). After the last Y address (Y = 5), Y wraps around to 0 and X increments to address the next column. In the horizontal addressing mode (V = 0), the X address increments after each byte (see Fig.6). After the last X address (X = 83), X wraps around to 0 and Y increments to address the next row. After the very last address (X = 83 and Y = 5), the address pointers wrap around to address (X = 0 and Y = 0).

7.7.1 DATA STRUCTURE

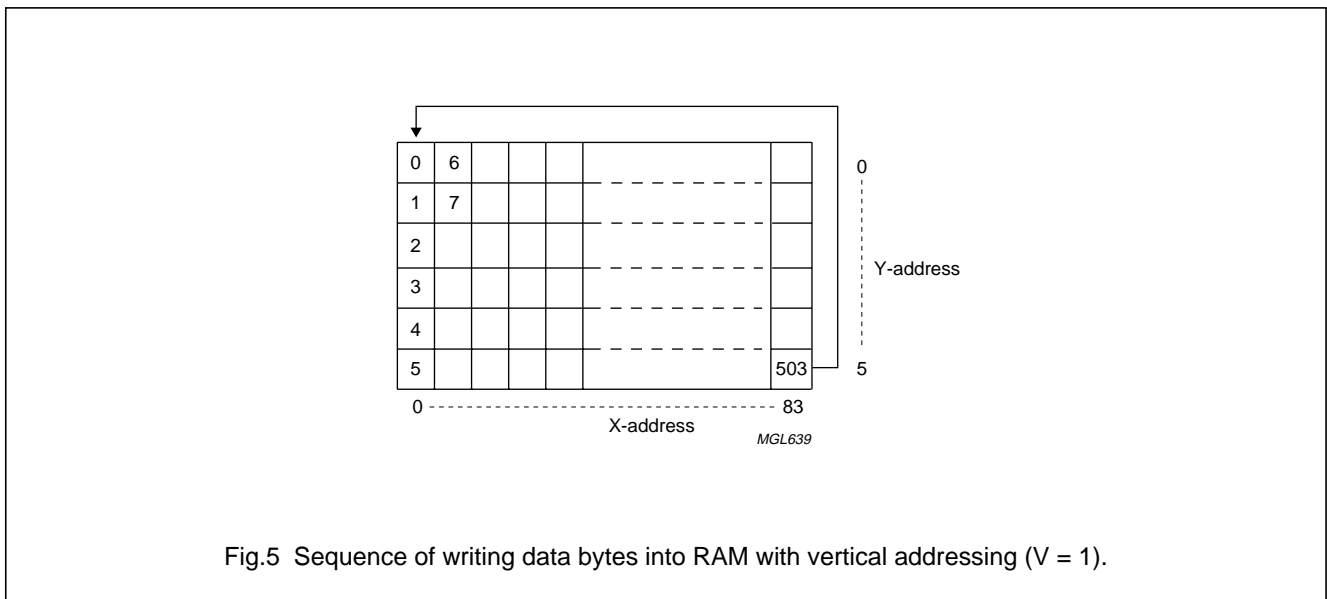
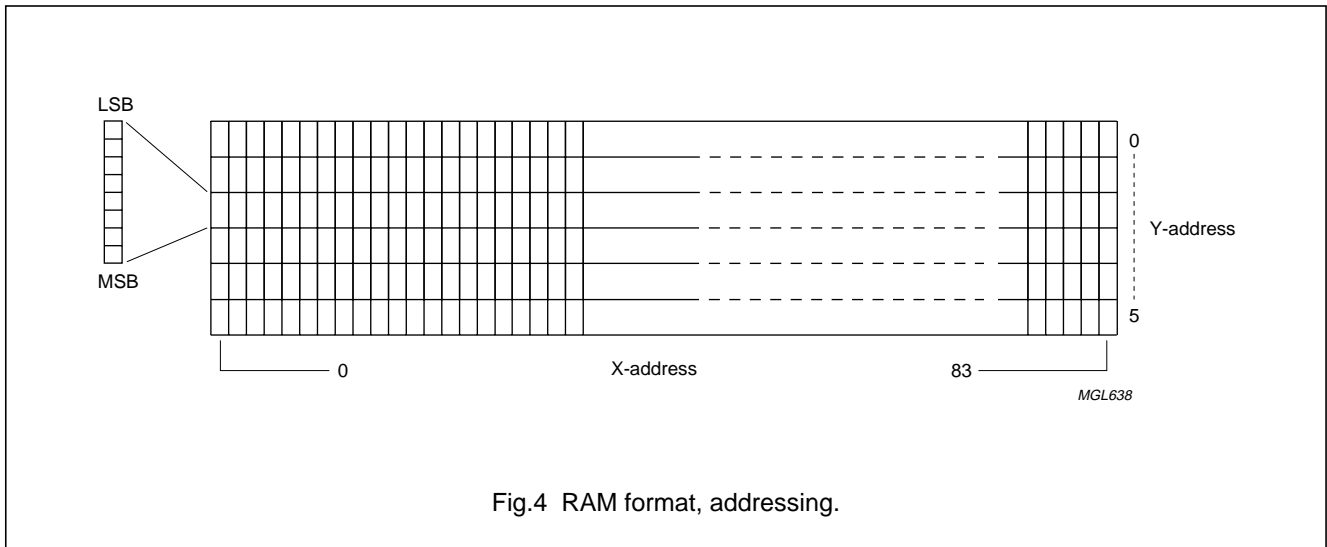

48 × 84 pixels matrix LCD controller/driver

PCD8544

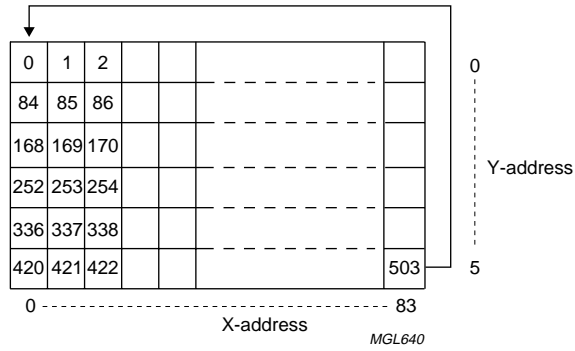
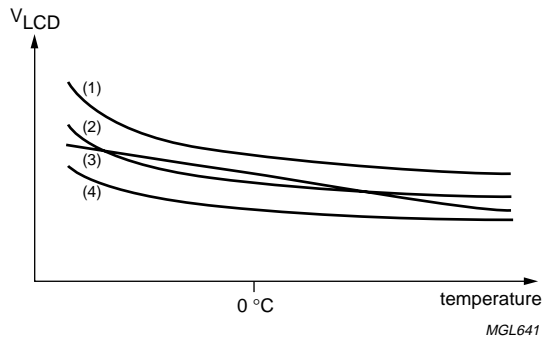

Fig.6 Sequence of writing data bytes into RAM with horizontal addressing (V = 0).

7.8 Temperature compensation

Due to the temperature dependency of the liquid crystals' viscosity, the LCD controlling voltage V_{LCD} must be increased at lower temperatures to maintain optimum

contrast. Figure 7 shows V_{LCD} for high multiplex rates. In the PCD8544, the temperature coefficient of V_{LCD} , can be selected from four values (see Table 2) by setting bits TC_1 and TC_0 .



- (1) Upper limit.
- (2) Typical curve.
- (3) Temperature coefficient of IC.
- (4) Lower limit.

Fig.7 V_{LCD} as function of liquid crystal temperature (typical values).

48 × 84 pixels matrix LCD controller/driver

PCD8544

8 INSTRUCTIONS

The instruction format is divided into two modes: If $\overline{D/\overline{C}}$ (mode select) is set LOW, the current byte is interpreted as command byte (see Table 1). Figure 8 shows an example of a serial data stream for initializing the chip. If $\overline{D/\overline{C}}$ is set HIGH, the following bytes are stored in the display data RAM. After every data byte, the address counter is incremented automatically.

The level of the $\overline{D/\overline{C}}$ signal is read during the last bit of data byte.

Each instruction can be sent in any order to the PCD8544. The MSB of a byte is transmitted first. Figure 9 shows one possible command stream, used to set up the LCD driver.

The serial interface is initialized when \overline{SCE} is HIGH. In this state, SCLK clock pulses have no effect and no power is consumed by the serial interface. A negative edge on \overline{SCE} enables the serial interface and indicates the start of a data transmission.

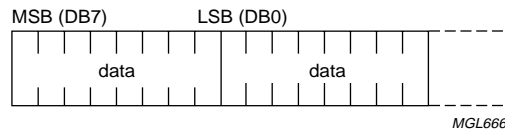

Fig.8 General format of data stream.

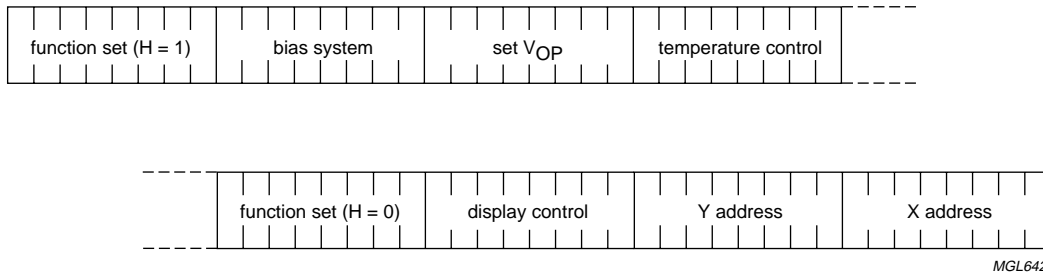

Fig.9 Serial data stream, example.

Figures 10 and 11 show the serial bus protocol.

- When \overline{SCE} is HIGH, SCLK clock signals are ignored; during the HIGH time of \overline{SCE} , the serial interface is initialized (see Fig.12)
- SDIN is sampled at the positive edge of SCLK
- $\overline{D/\overline{C}}$ indicates whether the byte is a command ($\overline{D/\overline{C}} = 0$) or RAM data ($\overline{D/\overline{C}} = 1$); it is read with the eighth SCLK pulse

- If \overline{SCE} stays LOW after the last bit of a command/data byte, the serial interface expects bit 7 of the next byte at the next positive edge of SCLK (see Fig.12)
- A reset pulse with \overline{RES} interrupts the transmission. No data is written into the RAM. The registers are cleared. If \overline{SCE} is LOW after the positive edge of \overline{RES} , the serial interface is ready to receive bit 7 of a command/data byte (see Fig.13).

48 × 84 pixels matrix LCD controller/driver

PCD8544

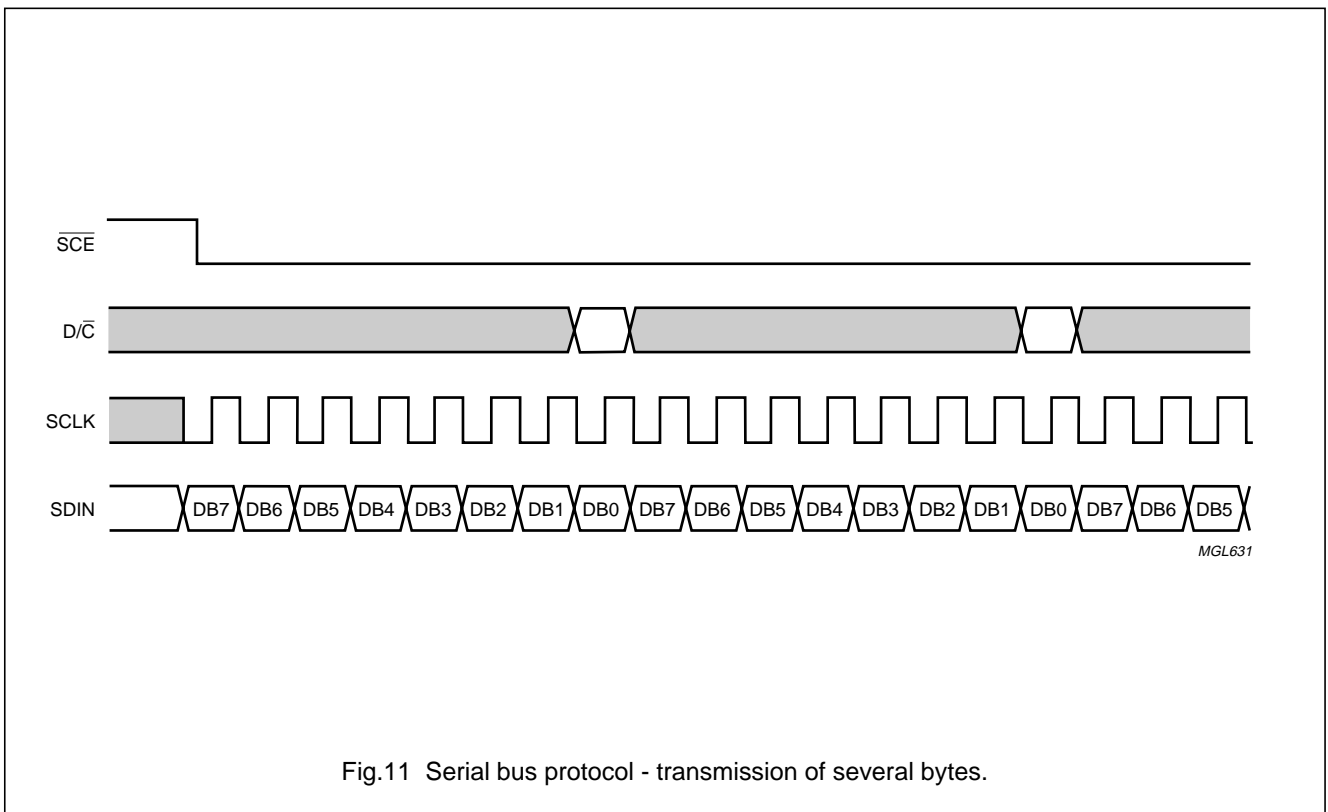
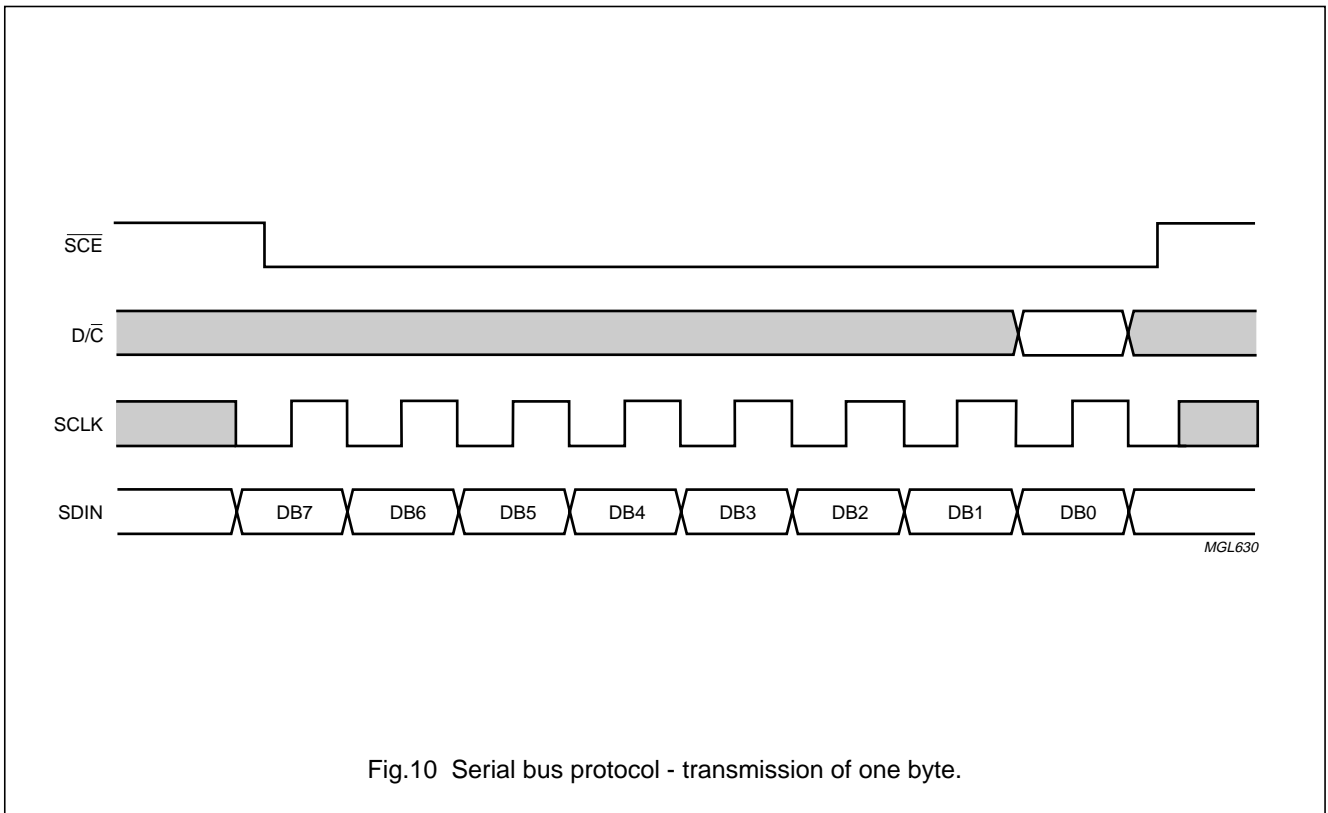

48 × 84 pixels matrix LCD controller/driver

PCD8544

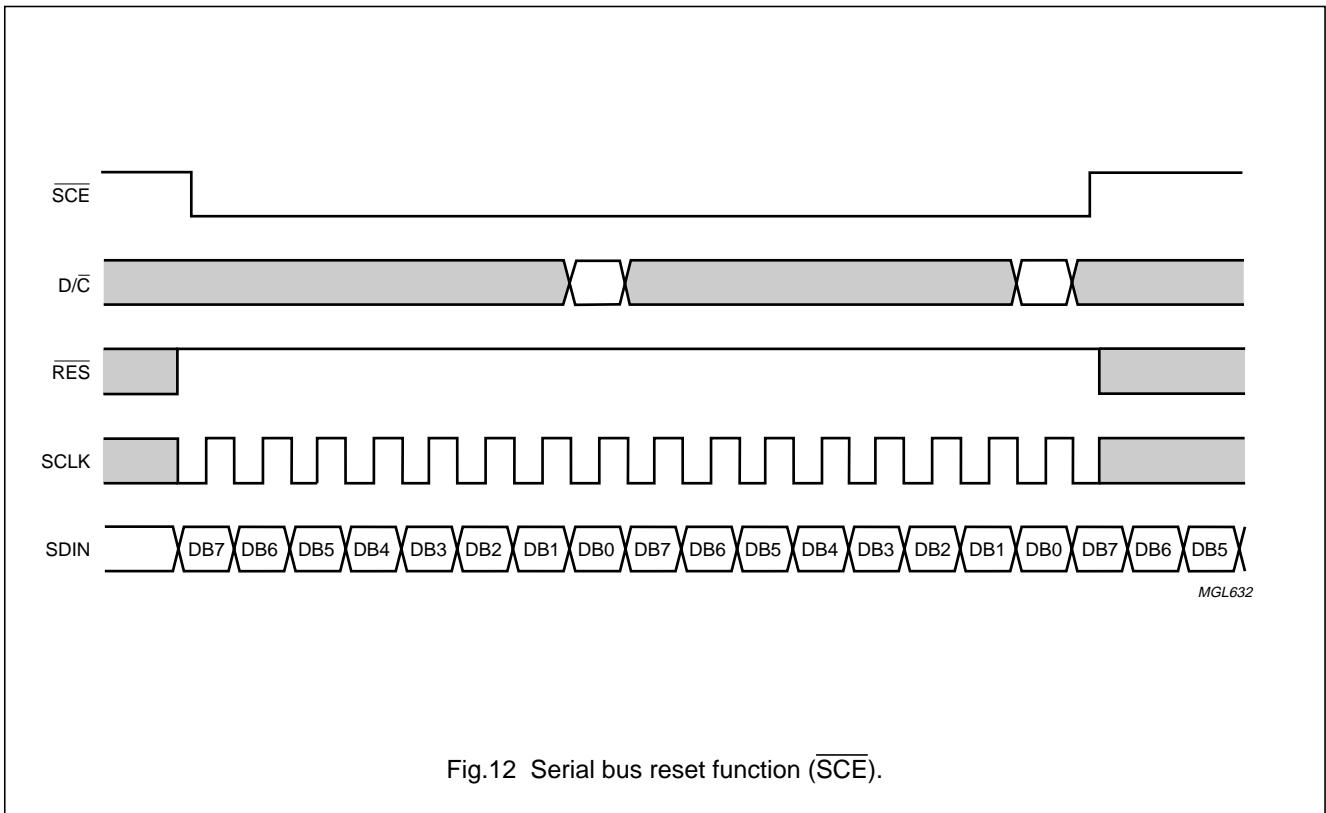

Fig.12 Serial bus reset function (\overline{SCE}).

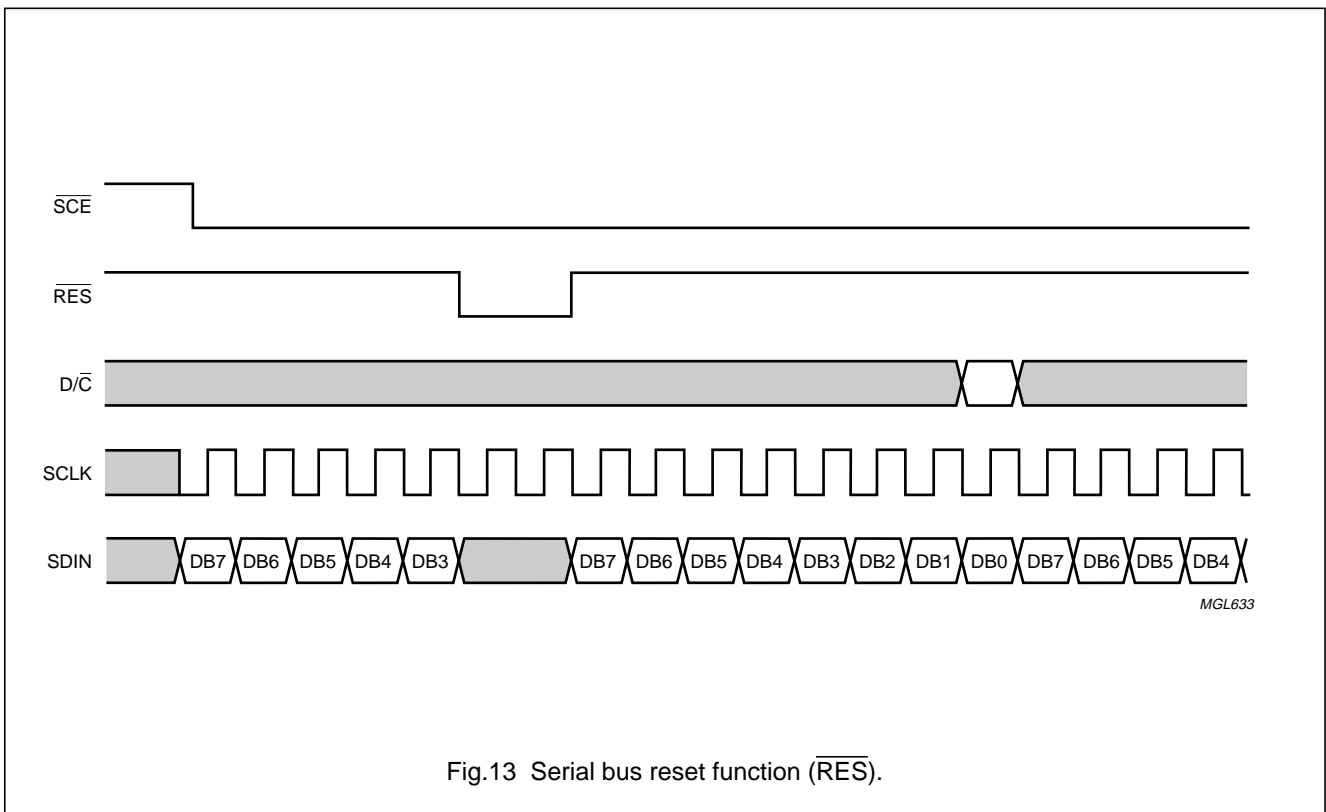

Fig.13 Serial bus reset function (\overline{RES}).

48 × 84 pixels matrix LCD controller/driver

PCD8544

Table 1 Instruction set

INSTRUCTION	D/C	COMMAND BYTE								DESCRIPTION	
		DB7	DB6	DB5	DB4	DB3	DB2	DB1	DB0		
(H = 0 or 1)											
NOP	0	0	0	0	0	0	0	0	0	0	no operation
Function set	0	0	0	1	0	0	PD	V	H		power down control; entry mode; extended instruction set control (H)
Write data	1	D ₇	D ₆	D ₅	D ₄	D ₃	D ₂	D ₁	D ₀		writes data to display RAM
(H = 0)											
Reserved	0	0	0	0	0	0	1	X	X		do not use
Display control	0	0	0	0	0	1	D	0	E		sets display configuration
Reserved	0	0	0	0	1	X	X	X	X		do not use
Set Y address of RAM	0	0	1	0	0	0	Y ₂	Y ₁	Y ₀		sets Y-address of RAM; 0 ≤ Y ≤ 5
Set X address of RAM	0	1	X ₆	X ₅	X ₄	X ₃	X ₂	X ₁	X ₀		sets X-address part of RAM; 0 ≤ X ≤ 83
(H = 1)											
Reserved	0	0	0	0	0	0	0	0	1		do not use
	0	0	0	0	0	0	0	1	X		do not use
Temperature control	0	0	0	0	0	0	1	TC ₁	TC ₀		set Temperature Coefficient (TC _x)
Reserved	0	0	0	0	0	1	X	X	X		do not use
Bias system	0	0	0	0	1	0	BS ₂	BS ₁	BS ₀		set Bias System (BS _x)
Reserved	0	0	1	X	X	X	X	X	X		do not use
Set V _{OP}	0	1	V _{OP6}	V _{OP5}	V _{OP4}	V _{OP3}	V _{OP2}	V _{OP1}	V _{OP0}		write V _{OP} to register

Table 2 Explanations of symbols in Table 1

BIT	0	1
PD	chip is active	chip is in Power-down mode
V	horizontal addressing	vertical addressing
H	use basic instruction set	use extended instruction set
D and E	display blank 00 normal mode 10 all display segments on 01 inverse video mode 11	
TC ₁ and TC ₀	V _{LCD} temperature coefficient 0 00 V _{LCD} temperature coefficient 1 01 V _{LCD} temperature coefficient 2 10 V _{LCD} temperature coefficient 3 11	

48 × 84 pixels matrix LCD controller/driver

PCD8544

8.1 Initialization

Immediately following power-on, the contents of all internal registers and of the RAM are undefined. A **RES pulse must be applied**. Attention should be paid to the possibility that the **device may be damaged** if not properly reset.

All internal registers are reset by applying an external $\overline{\text{RES}}$ pulse (active LOW) at pad 31, within the specified time. However, the RAM contents are still undefined. The state after reset is described in Section 8.2.

The $\overline{\text{RES}}$ input must be $\leq 0.3V_{\text{DD}}$ when V_{DD} reaches V_{DDmin} (or higher) within a maximum time of 100 ms after V_{DD} goes HIGH (see Fig.16).

8.2 Reset function

After reset, the LCD driver has the following state:

- Power-down mode (bit PD = 1)
- Horizontal addressing (bit V = 0) normal instruction set (bit H = 0)
- Display blank (bit E = D = 0)
- Address counter X_6 to $X_0 = 0$; Y_2 to $Y_0 = 0$
- Temperature control mode (TC_1 $\text{TC}_0 = 0$)
- Bias system (BS_2 to $\text{BS}_0 = 0$)
- V_{LCD} is equal to 0, the HV generator is switched off (V_{OP6} to $V_{\text{OP0}} = 0$)
- After power-on, the RAM contents are undefined.

8.3 Function set**8.3.1 BIT PD**

- All LCD outputs at V_{SS} (display off)
- Bias generator and V_{LCD} generator off, V_{LCD} can be disconnected
- Oscillator off (external clock possible)
- Serial bus, command, etc. function
- Before entering Power-down mode, the RAM needs to be filled with '0's to ensure the specified current consumption.

8.3.2 BIT V

When $V = 0$, the horizontal addressing is selected. The data is written into the DDRAM as shown in Fig.6. When $V = 1$, the vertical addressing is selected. The data is written into the DDRAM, as shown in Fig.5.

8.3.3 BIT H

When $H = 0$ the commands 'display control', 'set Y address' and 'set X address' can be performed; when $H = 1$, the others can be executed. The 'write data' and 'function set' commands can be executed in both cases.

8.4 Display control**8.4.1 BITS D AND E**

Bits D and E select the display mode (see Table 2).

8.5 Set Y address of RAM

Y_n defines the Y vector addressing of the display RAM.

Table 3 Y vector addressing

Y_2	Y_1	Y_0	BANK
0	0	0	0
0	0	1	1
0	1	0	2
0	1	1	3
1	0	0	4
1	0	1	5

8.6 Set X address of RAM

The X address points to the columns. The range of X is 0 to 83 (53H).

8.7 Temperature control

The temperature coefficient of V_{LCD} is selected by bits TC_1 and TC_0 .

8.8 Bias value

The bias voltage levels are set in the ratio of $R - R - nR - R - R$, giving a $1/(n + 4)$ bias system. Different multiplex rates require different factors n (see Table 4). This is programmed by BS_2 to BS_0 . For Mux 1 : 48, the optimum bias value n , resulting in 1/8 bias, is given by:

$$n = \sqrt{48} - 3 = 3.928 = 4 \quad (1)$$

48 × 84 pixels matrix LCD controller/driver

PCD8544

Table 4 Programming the required bias system

BS ₂	BS ₁	BS ₀	n	RECOMMENDED MUX RATE
0	0	0	7	1 : 100
0	0	1	6	1 : 80
0	1	0	5	1 : 65/1 : 65
0	1	1	4	1 : 48
1	0	0	3	1 : 40/1 : 34
1	0	1	2	1 : 24
1	1	0	1	1 : 18/1 : 16
1	1	1	0	1 : 10/1 : 9/1 : 8

Table 5 LCD bias voltage

SYMBOL	BIAS VOLTAGES	BIAS VOLTAGE FOR 1/8 BIAS
V1	V _{LCD}	V _{LCD}
V2	(n + 3)/(n + 4)	7/8 × V _{LCD}
V3	(n + 2)/(n + 4)	6/8 × V _{LCD}
V4	2/(n + 4)	2/8 × V _{LCD}
V5	1/(n + 4)	1/8 × V _{LCD}
V6	V _{SS}	V _{SS}

8.9 Set V_{OP} value

The operation voltage V_{LCD} can be set by software. The values are dependent on the liquid crystal selected. V_{LCD} = a + (V_{OP6} to V_{OP0}) × b [V]. In the PCD8544, a = 3.06 and b = 0.06 giving a program range of 3.00 to 10.68 at room temperature.

Note that the charge pump is turned off if V_{OP6} to V_{OP0} is set to zero.

For Mux 1 : 48, the optimum operation voltage of the liquid can be calculated as:

$$V_{LCD} = \frac{1 + \sqrt{48}}{\sqrt{2 \cdot \left(1 - \frac{1}{\sqrt{48}}\right)}} \cdot V_{th} = 6.06 \cdot V_{th} \quad (2)$$

where V_{th} is the threshold voltage of the liquid crystal material used.

Caution, as V_{OP} increases with lower temperatures, care must be taken not to set a V_{OP} that will exceed the maximum of 8.5 V when operating at -25 °C.

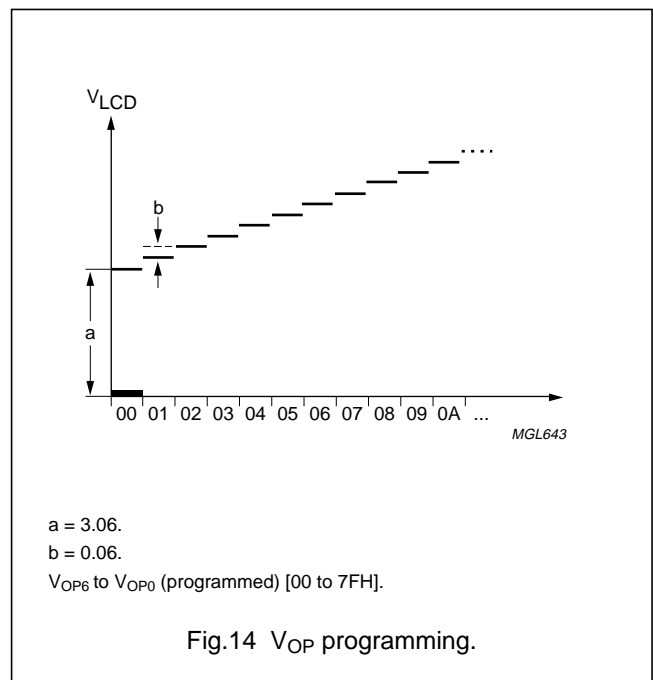

48 × 84 pixels matrix LCD controller/driver

PCD8544

9 LIMITING VALUES

In accordance with the Absolute Maximum Rating System (IEC 134); see notes 1 and 2.

SYMBOL	PARAMETER	CONDITIONS	MIN.	MAX.	UNIT
V_{DD}	supply voltage	note 3	-0.5	+7	V
V_{LCD}	supply voltage LCD	note 4	-0.5	+10	V
V_i	all input voltages		-0.5	$V_{DD} + 0.5$	V
I_{SS}	ground supply current		-50	+50	mA
I_i, I_o	DC input or output current		-10	+10	mA
P_{tot}	total power dissipation		-	300	mW
P_o	power dissipation per output		-	30	mW
T_{amb}	operating ambient temperature		-25	+70	°C
T_j	operating junction temperature		-65	+150	°C
T_{stg}	storage temperature		-65	+150	°C

Notes

1. Stresses above those listed under limiting values may cause permanent damage to the device.
2. Parameters are valid over operating temperature range unless otherwise specified. All voltages are with respect to V_{SS} unless otherwise noted.
3. With external LCD supply voltage externally supplied (voltage generator disabled). $V_{DDmax} = 5$ V if LCD supply voltage is internally generated (voltage generator enabled).
4. When setting V_{LCD} by software, take care not to set a V_{OP} that will exceed the maximum of 8.5 V when operating at -25 °C, see Caution in Section 8.9.

10 HANDLING

Inputs and outputs are protected against electrostatic discharge in normal handling. However, to be totally safe, it is desirable to take normal precautions appropriate to handling MOS devices (see "Handling MOS devices").

48 × 84 pixels matrix LCD controller/driver

PCD8544

11 DC CHARACTERISTICS

$V_{DD} = 2.7$ to 3.3 V; $V_{SS} = 0$ V; $V_{LCD} = 6.0$ to 9.0 V; $T_{amb} = -25$ to $+70$ °C; unless otherwise specified.

SYMBOL	PARAMETER	CONDITIONS	MIN.	TYP.	MAX.	UNIT
V_{DD1}	supply voltage 1	LCD voltage externally supplied (voltage generator disabled)	2.7	–	3.3	V
V_{DD2}	supply voltage 2	LCD voltage internally generated (voltage generator enabled)	2.7	–	3.3	V
V_{LCD1}	LCD supply voltage	LCD voltage externally supplied (voltage generator disabled)	6.0	–	9.0	V
V_{LCD2}	LCD supply voltage	LCD voltage internally generated (voltage generator enabled); note 1	6.0	–	8.5	V
I_{DD1}	supply current 1 (normal mode) for internal V_{LCD}	$V_{DD} = 2.85$ V; $V_{LCD} = 7.0$ V; $f_{SCLK} = 0$; $T_{amb} = 25$ °C; display load = 10 μ A; note 2	–	240	300	μ A
I_{DD2}	supply current 2 (normal mode) for internal V_{LCD}	$V_{DD} = 2.70$ V; $V_{LCD} = 7.0$ V; $f_{SCLK} = 0$; $T_{amb} = 25$ °C; display load = 10 μ A; note 2	–	–	320	μ A
I_{DD3}	supply current 3 (Power-down mode)	with internal or external LCD supply voltage; note 3	–	1.5	–	μ A
I_{DD4}	supply current external V_{LCD}	$V_{DD} = 2.85$ V; $V_{LCD} = 9.0$ V; $f_{SCLK} = 0$; notes 2 and 4	–	25	–	μ A
I_{LCD}	supply current external V_{LCD}	$V_{DD} = 2.7$ V; $V_{LCD} = 7.0$ V; $f_{SCLK} = 0$; $T = 25$ °C; display load = 10 μ A; notes 2 and 4	–	42	–	μ A
Logic						
V_{IL}	LOW level input voltage		V_{SS}	–	$0.3V_{DD}$	V
V_{IH}	HIGH level input voltage		$0.7V_{DD}$	–	V_{DD}	V
I_L	leakage current	$V_I = V_{DD}$ or V_{SS}	–1	–	+1	μ A
Column and row outputs						
$R_{O(C)}$	column output resistance C0 to C83		–	12	20	k Ω
$R_{O(R)}$	row output resistance R0 to R47		–	12	20	k Ω
$V_{bias(tol)}$	bias voltage tolerance on C0 to C83 and R0 to R47		–100	0	+100	mV

48 × 84 pixels matrix LCD controller/driver

PCD8544

SYMBOL	PARAMETER	CONDITIONS	MIN.	TYP.	MAX.	UNIT
LCD supply voltage generator						
V _{LCD}	V _{LCD} tolerance internally generated	V _{DD} = 2.85 V; V _{LCD} = 7.0 V; f _{SCLK} = 0; display load = 10 μA; note 5	–	0	300	mV
TC0	V _{LCD} temperature coefficient 0	V _{DD} = 2.85 V; V _{LCD} = 7.0 V; f _{SCLK} = 0; display load = 10 μA	–	1	–	mV/K
TC1	V _{LCD} temperature coefficient 1	V _{DD} = 2.85 V; V _{LCD} = 7.0 V; f _{SCLK} = 0; display load = 10 μA	–	9	–	mV/K
TC2	V _{LCD} temperature coefficient 2	V _{DD} = 2.85 V; V _{LCD} = 7.0 V; f _{SCLK} = 0; display load = 10 μA	–	17	–	mV/K
TC3	V _{LCD} temperature coefficient 3	V _{DD} = 2.85 V; V _{LCD} = 7.0 V; f _{SCLK} = 0; display load = 10 μA	–	24	–	mV/K

Notes

1. The maximum possible V_{LCD} voltage that may be generated is dependent on voltage, temperature and (display) load.
2. Internal clock.
3. RAM contents equal '0'. During power-down, all static currents are switched off.
4. If external V_{LCD}, the display load current is not transmitted to I_{DD}.
5. Tolerance depends on the temperature (typically zero at 27 °C, maximum tolerance values are measured at the temperate range limit).

48 × 84 pixels matrix LCD controller/driver

PCD8544

12 AC CHARACTERISTICS

SYMBOL	PARAMETER	CONDITIONS	MIN.	TYP.	MAX.	UNIT
f _{OSC}	oscillator frequency		20	34	65	kHz
f _{clk(ext)}	external clock frequency		10	32	100	kHz
f _{frame}	frame frequency	f _{OSC} or f _{clk(ext)} = 32 kHz; note 1	–	67	–	Hz
t _{VHRL}	V _{DD} to $\overline{\text{RES}}$ LOW	Fig.16	0 ⁽²⁾	–	30	ms
t _{WL(RES)}	$\overline{\text{RES}}$ LOW pulse width	Fig.16	100	–	–	ns
Serial bus timing characteristics						
f _{SCLK}	clock frequency	V _{DD} = 3.0 V ±10%	0	–	4.00	MHz
T _{cy}	clock cycle SCLK	All signal timing is based on 20% to 80% of V _{DD} and maximum rise and fall times of 10 ns	250	–	–	ns
t _{WH1}	SCLK pulse width HIGH		100	–	–	ns
t _{WL1}	SCLK pulse width LOW		100	–	–	ns
t _{su2}	$\overline{\text{SCE}}$ set-up time		60	–	–	ns
t _{h2}	$\overline{\text{SCE}}$ hold time		100	–	–	ns
t _{WH2}	$\overline{\text{SCE}}$ min. HIGH time		100	–	–	ns
t _{h5}	$\overline{\text{SCE}}$ start hold time; note 3		100	–	–	ns
t _{su3}	D/C set-up time		100	–	–	ns
t _{h3}	D/C hold time		100	–	–	ns
t _{su4}	SDIN set-up time		100	–	–	ns
t _{h4}	SDIN hold time	100	–	–	ns	

Notes

- $T_{\text{frame}} = \frac{f_{\text{clk}(\text{ext})}}{480}$
- $\overline{\text{RES}}$ may be LOW before V_{DD} goes HIGH.
- t_{h5} is the time from the previous SCLK positive edge (irrespective of the state of $\overline{\text{SCE}}$) to the negative edge of $\overline{\text{SCE}}$ (see Fig.15).

48 × 84 pixels matrix LCD controller/driver

PCD8544

12.1 Serial interface

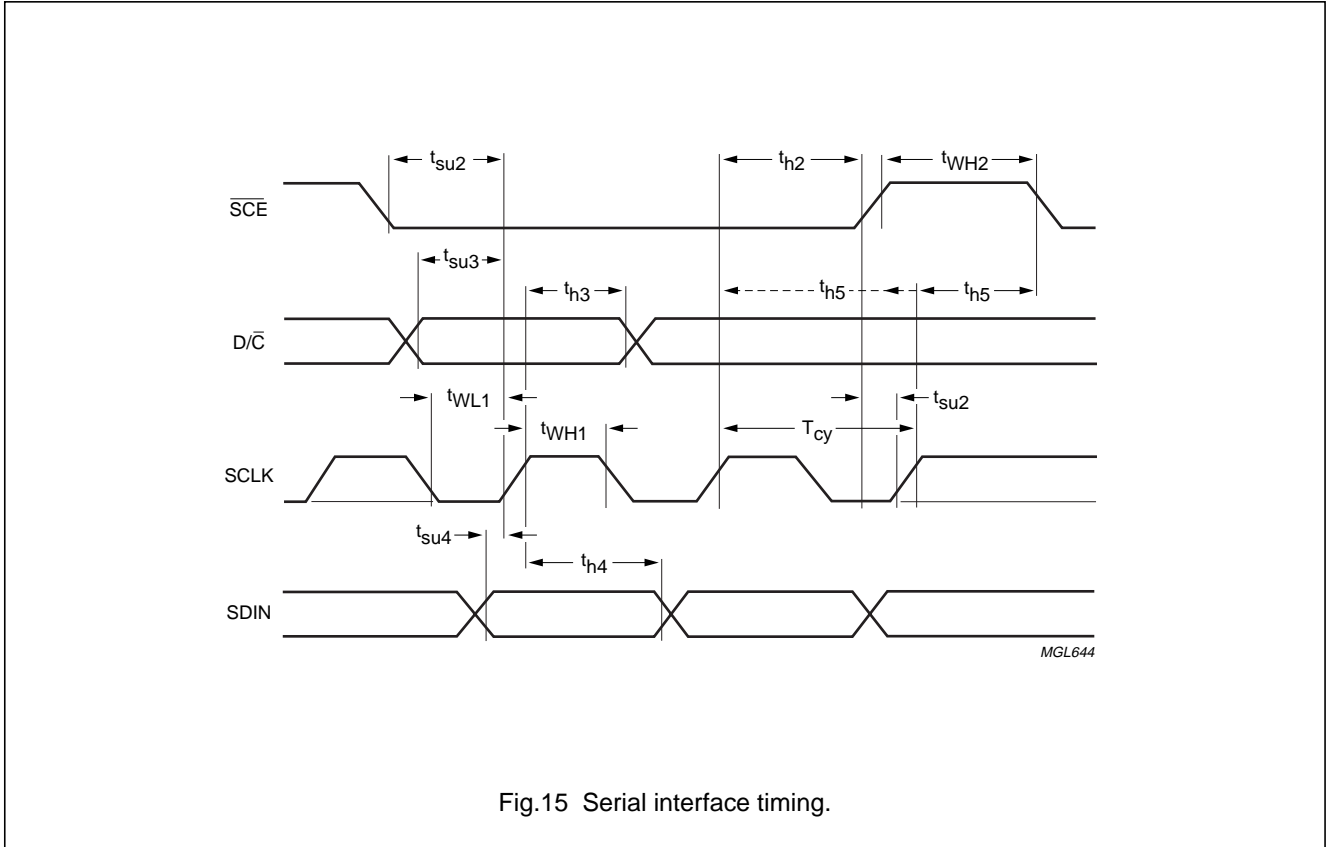

Fig.15 Serial interface timing.

12.2 Reset

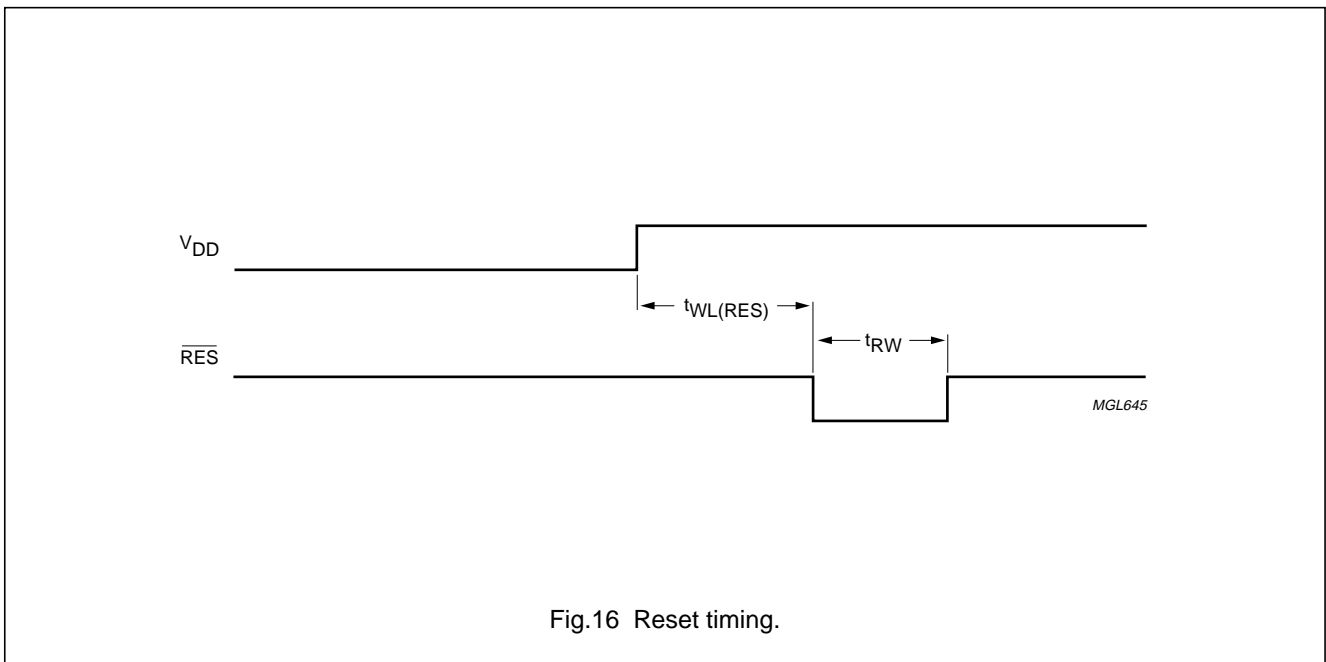

Fig.16 Reset timing.

48 × 84 pixels matrix LCD controller/driver

PCD8544

13 APPLICATION INFORMATION

Table 6 Programming example

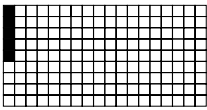
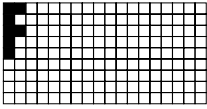
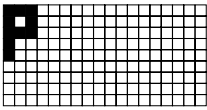
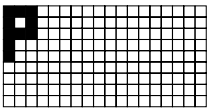
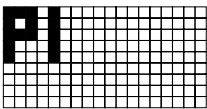
STEP	SERIAL BUS BYTE									DISPLAY	OPERATION
	D/C	DB7	DB6	DB5	DB4	DB3	DB2	DB1	DB0		
1	start										SCE is going LOW
2	0	0	0	1	0	0	0	0	1		function set PD = 0 and V = 0, select extended instruction set (H = 1 mode)
3	0	1	0	0	1	0	0	0	0		set V _{OP} ; V _{OP} is set to a +16 × b [V]
4	0	0	0	1	0	0	0	0	0		function set PD = 0 and V = 0, select normal instruction set (H = 0 mode)
5	0	0	0	0	0	1	1	0	0		display control set normal mode (D = 1 and E = 0)
6	1	0	0	0	1	1	1	1	1	 <small>MGL673</small>	data write Y and X are initialized to 0 by default, so they are not set here
7	1	0	0	0	0	0	1	0	1	 <small>MGL674</small>	data write
8	1	0	0	0	0	0	1	1	1	 <small>MGL675</small>	data write
9	1	0	0	0	0	0	0	0	0	 <small>MGL675</small>	data write
10	1	0	0	0	1	1	1	1	1	 <small>MGL676</small>	data write

48 × 84 pixels matrix LCD controller/driver

PCD8544

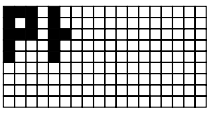
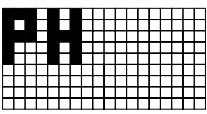
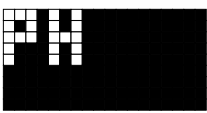
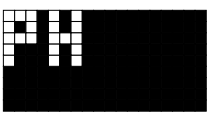
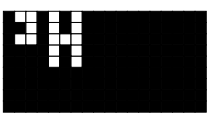
STEP	SERIAL BUS BYTE									DISPLAY	OPERATION
	D/C	DB7	DB6	DB5	DB4	DB3	DB2	DB1	DB0		
11	1	0	0	0	0	0	1	0	0		data write
12	1	0	0	0	1	1	1	1	1		data write
13	0	0	0	0	0	1	1	0	1		display control; set inverse video mode (D = 1 and E = 1)
14	0	1	0	0	0	0	0	0	0		set X address of RAM; set address to '0000000'
15	1	0	0	0	0	0	0	0	0		data write

The pinning is optimized for single plane wiring e.g. for chip-on-glass display modules. Display size: 48 × 84 pixels.

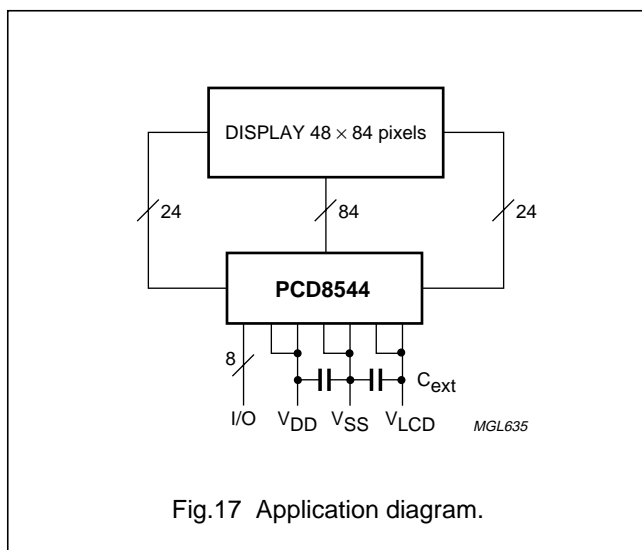

The required minimum value for the external capacitors is: $C_{ext} = 1.0 \mu F$.

Higher capacitor values are recommended for ripple reduction.

14 BONDING PAD LOCATIONS

14.1 Bonding pad information (see Fig.18)

PARAMETER	SIZE
Pad pitch	min. 100 μm
Pad size, aluminium	80 × 100 μm
Bump dimensions	59 × 89 × 17.5 (± 5) μm
Wafer thickness	max. 380 μm

48 × 84 pixels matrix LCD controller/driver

PCD8544

14.2 Bonding pad location

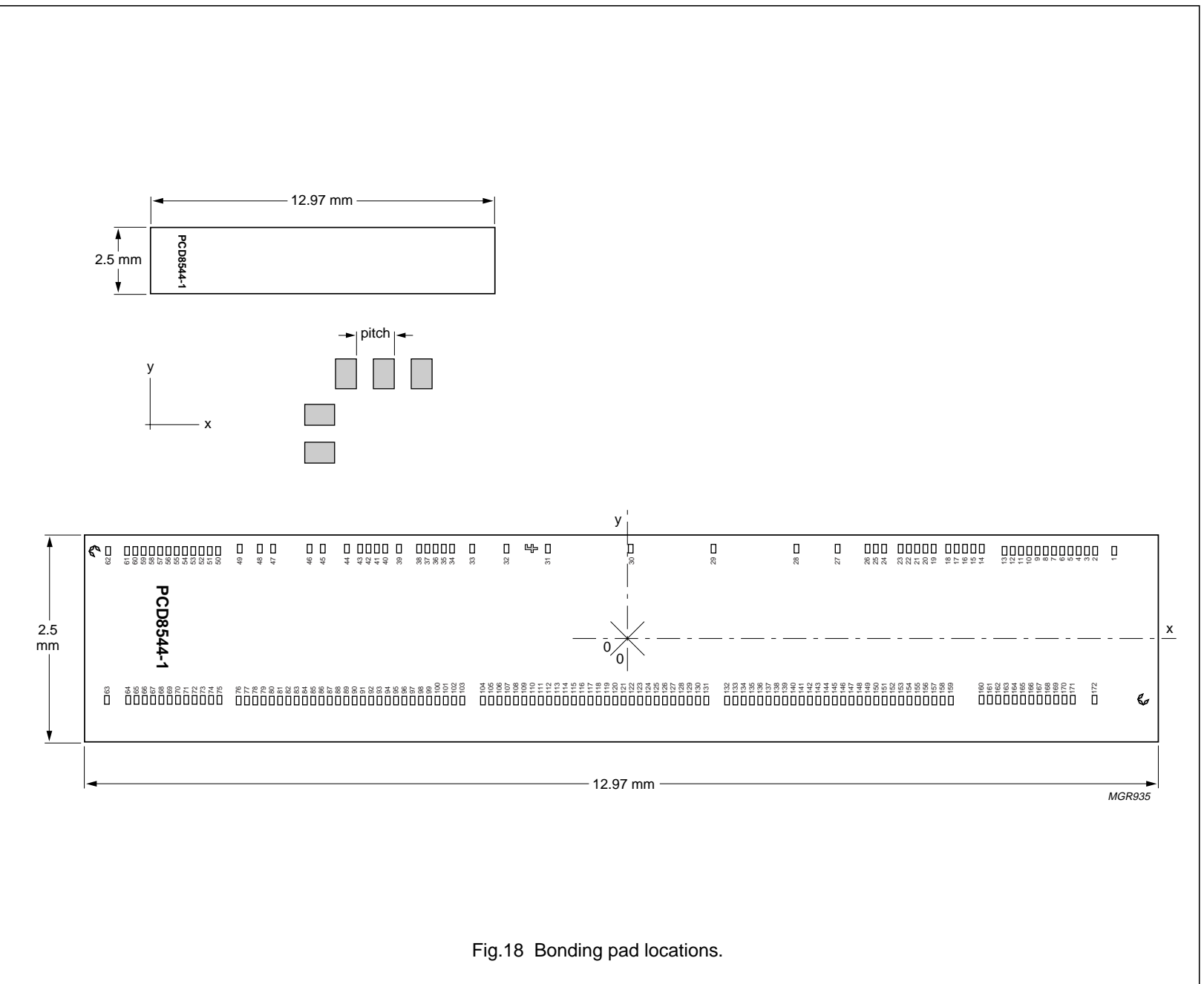

Fig.18 Bonding pad locations.

48 × 84 pixels matrix LCD controller/driver

PCD8544

Table 7 Bonding pad locations (dimensions in μm).
All X/Y coordinates are referenced to the centre
of chip (see Fig.18)

PAD	PAD NAME	x	y
1	dummy1	+5932	+1060
2	R36	+5704	+1060
3	R37	+5604	+1060
4	R38	+5504	+1060
5	R39	+5404	+1060
6	R40	+5304	+1060
7	R41	+5204	+1060
8	R42	+5104	+1060
9	R43	+5004	+1060
10	R44	+4904	+1060
11	R45	+4804	+1060
12	R46	+4704	+1060
13	R47	+4604	+1060
14	V _{DD1}	+4330	+1085
15	V _{DD1}	+4230	+1085
16	V _{DD1}	+4130	+1085
17	V _{DD1}	+4030	+1085
18	V _{DD1}	+3930	+1085
19	V _{DD2}	+3750	+1085
20	V _{DD2}	+3650	+1085
21	V _{DD2}	+3550	+1085
22	V _{DD2}	+3450	+1085
23	V _{DD2}	+3350	+1085
24	V _{DD2}	+3250	+1085
25	V _{DD2}	+3150	+1085
26	V _{DD2}	+3050	+1085
27	SCLK	+2590	+1085
28	SDIN	+2090	+1085
29	D/C	+1090	+1085
30	SCE	+90	+1085
31	RES	-910	+1085
32	OSC	-1410	+1085
33	T3	-1826	+1085
34	V _{SS2}	-2068	+1085
35	V _{SS2}	-2168	+1085
36	V _{SS2}	-2268	+1085
37	V _{SS2}	-2368	+1085
38	V _{SS2}	-2468	+1085

PAD	PAD NAME	x	y
39	T4	-2709	+1085
40	V _{SS1}	-2876	+1085
41	V _{SS1}	-2976	+1085
42	V _{SS1}	-3076	+1085
43	V _{SS1}	-3176	+1085
44	T1	-3337	+1085
45	V _{LCD2}	-3629	+1085
46	V _{LCD2}	-3789	+1085
47	V _{LCD1}	-4231	+1085
48	V _{LCD1}	-4391	+1085
49	T2	-4633	+1085
50	R23	-4894	+1060
51	R22	-4994	+1060
52	R21	-5094	+1060
53	R20	-5194	+1060
54	R19	-5294	+1060
55	R18	-5394	+1060
56	R17	-5494	+1060
57	R16	-5594	+1060
58	R15	-5694	+1060
59	R14	-5794	+1060
60	R13	-5894	+1060
61	R12	-5994	+1060
62	dummy2	-6222	+1060
63	dummy3	-6238	-738
64	R0	-5979	-738
65	R1	-5879	-738
66	R2	-5779	-738
67	R3	-5679	-738
68	R4	-5579	-738
69	R5	-5479	-738
70	R6	-5379	-738
71	R7	-5279	-738
72	R8	-5179	-738
73	R9	-5079	-738
74	R10	-4979	-738
75	R11	-4879	-738
76	C0	-4646	-746

48 × 84 pixels matrix LCD controller/driver

PCD8544

PAD	PAD NAME	x	y
77	C1	-4546	-746
78	C2	-4446	-746
79	C3	-4346	-746
80	C4	-4246	-746
81	C5	-4146	-746
82	C6	-4046	-746
83	C7	-3946	-746
84	C8	-3846	-746
85	C9	-3746	-746
86	C10	-3646	-746
87	C11	-3546	-746
88	C12	-3446	-746
89	C13	-3346	-746
90	C14	-3246	-746
91	C15	-3146	-746
92	C16	-3046	-746
93	C17	-2946	-746
94	C18	-2846	-746
95	C19	-2746	-746
96	C20	-2646	-746
97	C21	-2546	-746
98	C22	-2446	-746
99	C23	-2346	-746
100	C24	-2246	-746
101	C25	-2146	-746
102	C26	-2046	-746
103	C27	-1946	-746
104	C28	-1696	-746
105	C29	-1596	-746
106	C30	-1496	-746
107	C31	-1396	-746
108	C32	-1296	-746
109	C33	-1196	-746
110	C34	-1096	-746
111	C35	-996	-746
112	C36	-896	-746
113	C37	-796	-746
114	C38	-696	-746
115	C39	-596	-746
116	C40	-496	-746
117	C41	-396	-746

PAD	PAD NAME	x	y
118	C42	-296	-746
119	C43	-196	-746
120	C44	-96	-746
121	C45	+4	-746
122	C46	+104	-746
123	C47	+204	-746
124	C48	+304	-746
125	C49	+404	-746
126	C50	+504	-746
127	C51	+604	-746
128	C52	+704	-746
139	C53	+804	-746
130	C54	+904	-746
131	C55	+1004	-746
132	C56	+1254	-746
133	C57	+1354	-746
134	C58	+1454	-746
135	C59	+1554	-746
136	C60	+1654	-746
137	C61	+1754	-746
138	C62	+1854	-746
139	C63	+1954	-746
140	C64	+2054	-746
141	C65	+2154	-746
142	C66	+2254	-746
143	C67	+2354	-746
144	C68	+2454	-746
145	C69	+2554	-746
146	C70	+2654	-746
147	C71	+2754	-746
148	C72	+2854	-746
149	C73	+2954	-746
150	C74	+3054	-746
151	C75	+3154	-746
152	C76	+3254	-746
153	C77	+3354	-746
154	C78	+3454	-746
155	C79	+3554	-746
156	C80	+3654	-746
157	C81	+3754	-746
158	C82	+3854	-746

48 × 84 pixels matrix LCD controller/driver**PCD8544**

PAD	PAD NAME	x	y
159	C83	+3954	-746
160	R35	+4328	-738
161	R34	+4428	-738
162	R33	+4528	-738
163	R32	+4628	-738
164	R31	+4728	-738
165	R30	+4828	-738
166	R29	+4928	-738
167	R28	+5028	-738
168	R27	+5128	-738
169	R26	+5228	-738
170	R25	+5328	-738
171	R24	+5428	-738
172	dummy4	+5694	-738

48 × 84 pixels matrix LCD controller/driver

PCD8544

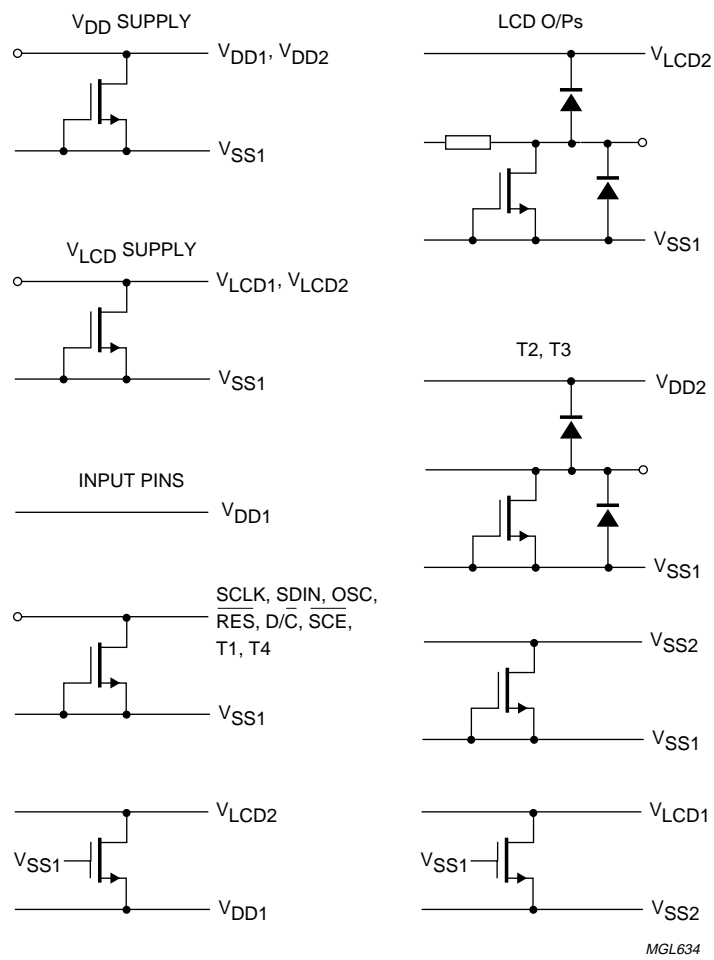

Fig.19 Device protection diagram.

48 × 84 pixels matrix LCD controller/driver

PCD8544

15 TRAY INFORMATION

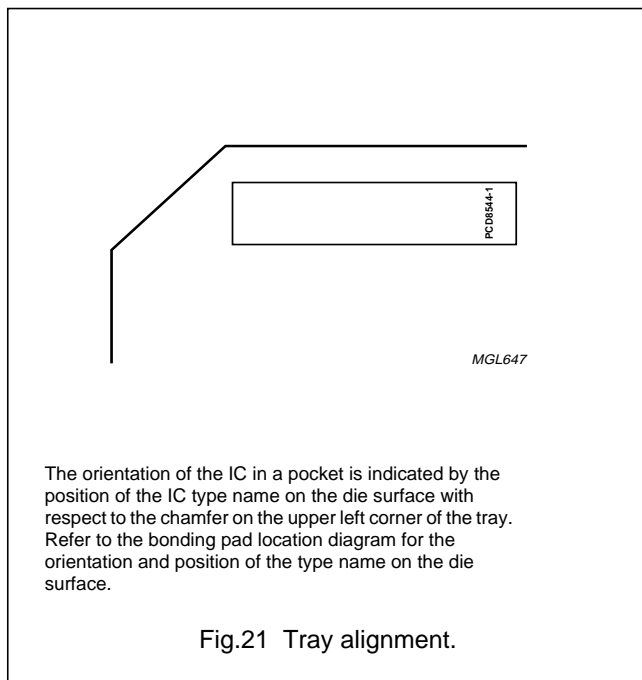
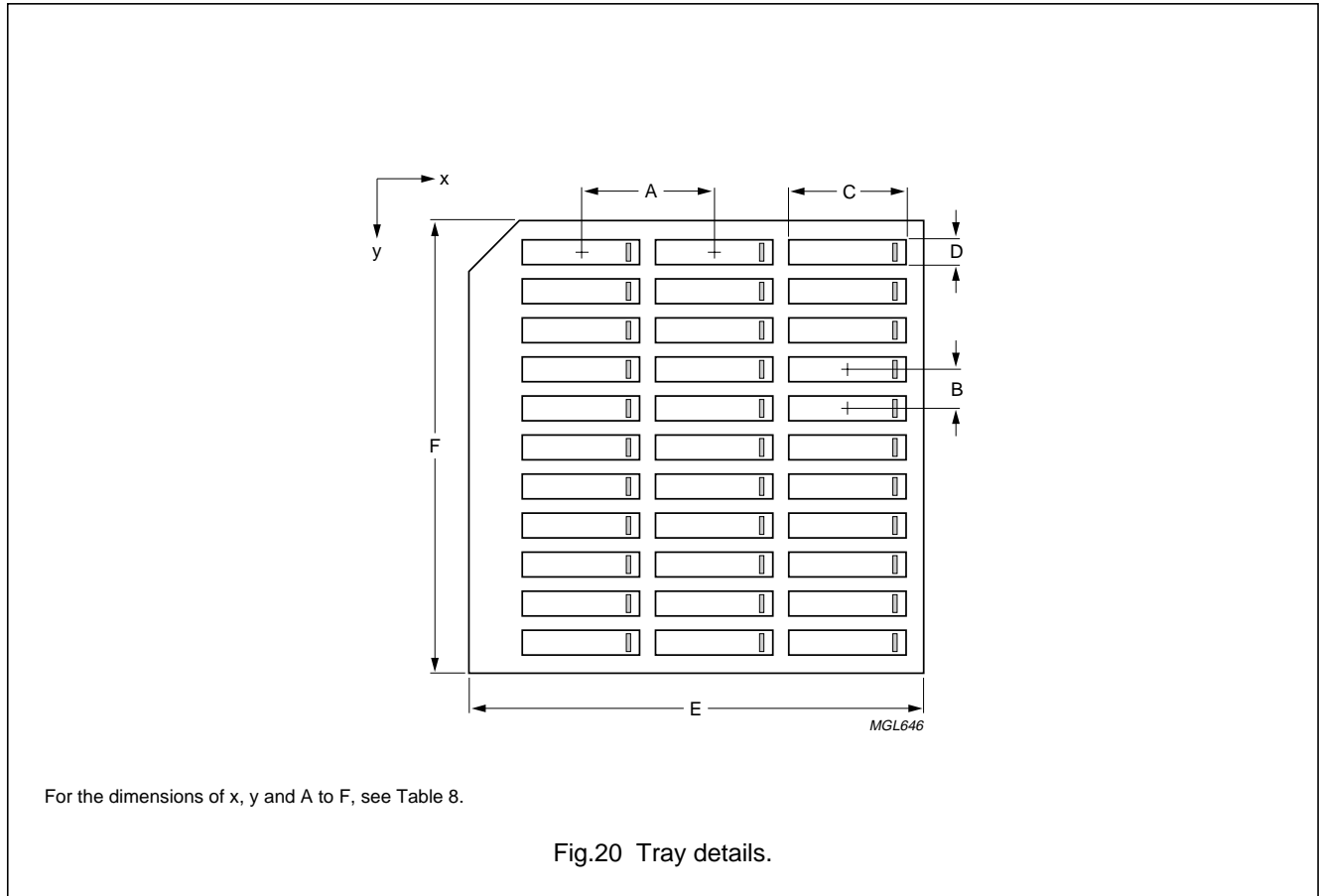

Table 8 Dimensions

DIM.	DESCRIPTION	VALUE
A	pocket pitch, in the x direction	14.82 mm
B	pocket pitch, in the y direction	4.39 mm
C	pocket width, in the x direction	13.27 mm
D	pocket width, in the y direction	2.8 mm
E	tray width, in the x direction	50.67 mm
F	tray width, in the y direction	50.67 mm
x	no. of pockets in the x direction	3
y	no. of pockets in the y direction	11