

# PS-LX40/LX40P/LX43P/LX44P

## SERVICE MANUAL

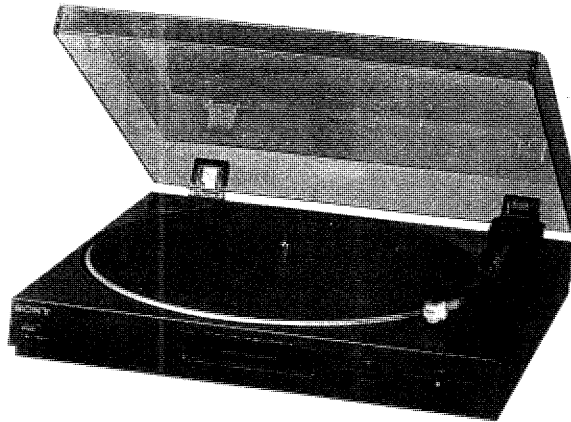

Photo : PS-LX40

*US Model*  
PS-LX43P

*AEP Model*  
PS-LX40P/LX43P

*UK Model*  
PS-LX40P/LX43P/LX44P

*E Model*  
PS-LX40/LX40P/LX43P

### SPECIFICATIONS

#### Turntable

Platter	30 cm
Motor	DC servo motor
Drive system	Belt drive
Speed	33 $\frac{1}{3}$ rpm/45 rpm switchable
Wow and flutter	0.2% (WRMS)
Signal-to-noise ratio	50 dB (DIN-B)
Automatic system	Return, reject

#### Tonearm

Type	Statically balanced
Pivot-to stylus length	203 mm
Overall arm length	235 mm

#### Cartridge

Type	Moving magnet type
Frequency response	20 Hz - 20kHz
Stylus	ND-155G

#### General

Dimensions	Approx. 355 x 95 x 345 mm (14 x 3 $\frac{3}{4}$ x 13 $\frac{5}{8}$ inches)
Weight	PS-LX40 : Approx. 2.5 kg PS-LX40P/LX43P/LX44P : Approx. 2.1 kg (4 lb 11 oz)
Power requirements	PS-LX40: 110 - 120 V, 220 - 240 V AC adjustable, 50/60 Hz PS-LX40P/LX43P/LX44P : 12V DC. Supplied from STEREO DECK RECEIVER (HST-).
Power consumption	4 W
Accessory supplied	45-rpm adaptor (1)
Optional accessories	Replacement stylus ND-155G

### REPLACING THE STYLUS

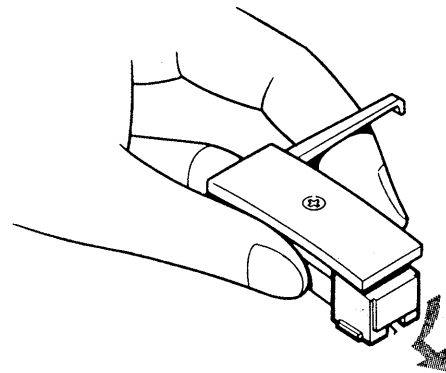

Replace the stylus after about 400 hours of use because using a worn stylus will damage records. An ND-155G replacement stylus is available at your Sony dealer. Be sure to turn the amplifier off before proceeding with replacement.

- 1 While holding the cartridge, detach the stylus assembly as illustrated.
- 2 Insert the new stylus into the cartridge.

Design and specifications subject to change without notice.

STEREO TURNTABLE SYSTEM  
**SONY**®

**REPAIRING PRECAUTION (PS-LX40P/LX43P/LX44P only)**

**[To supply B+ voltage]**

The power of this unit is fed from HST-D201, D301, D301CD or D501CD. Because of this, connect the regulated power supply as illustrated right when this unit alone operates.

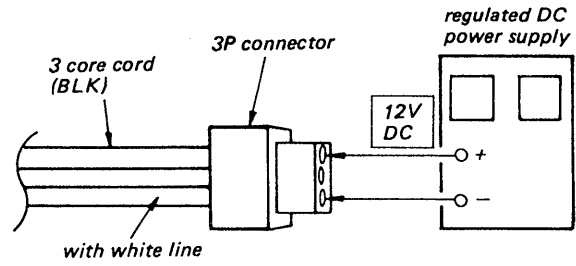

**LOCATION AND FUNCTION OF CONTROLS**

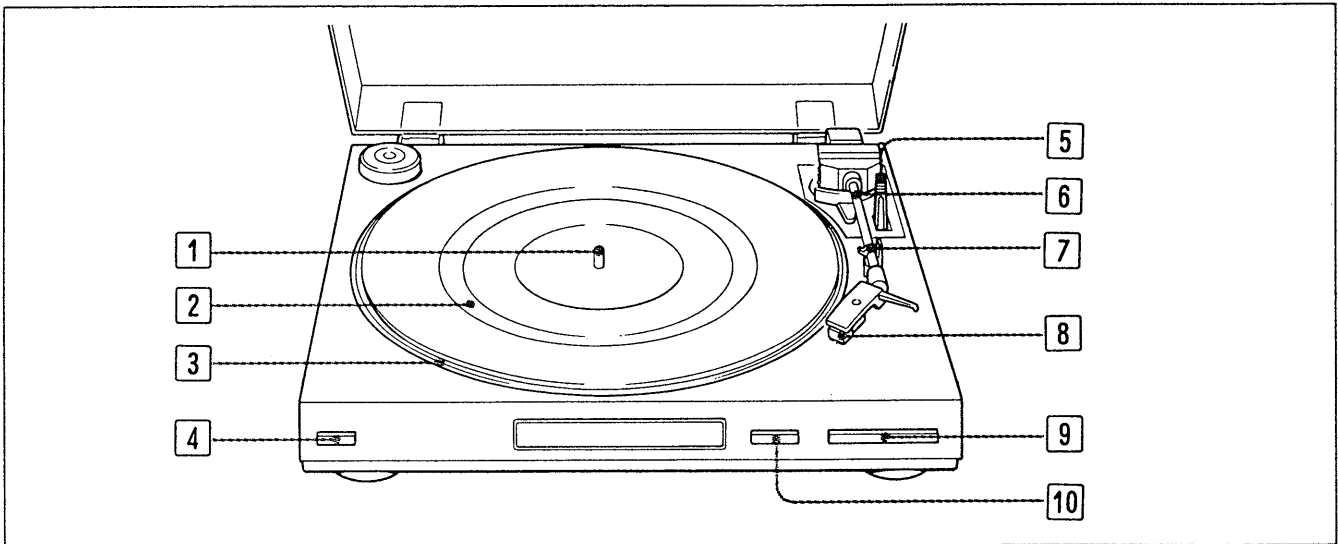

- 1 Center spindle
- 2 Rubber mat
- 3 Turntable platter
- 4 POWER switch (PS-LX40 only)
- 5 Cueing lever (▼/▼)
- 6 Tonearm
- 7 Arm rest
- 8 Cartridge
- 9 REJECT button
- 10 SPEED select button  
Allows selection of 45 rpm or 33 rpm turntable speed.

## TURNTABLE ASSEMBLY

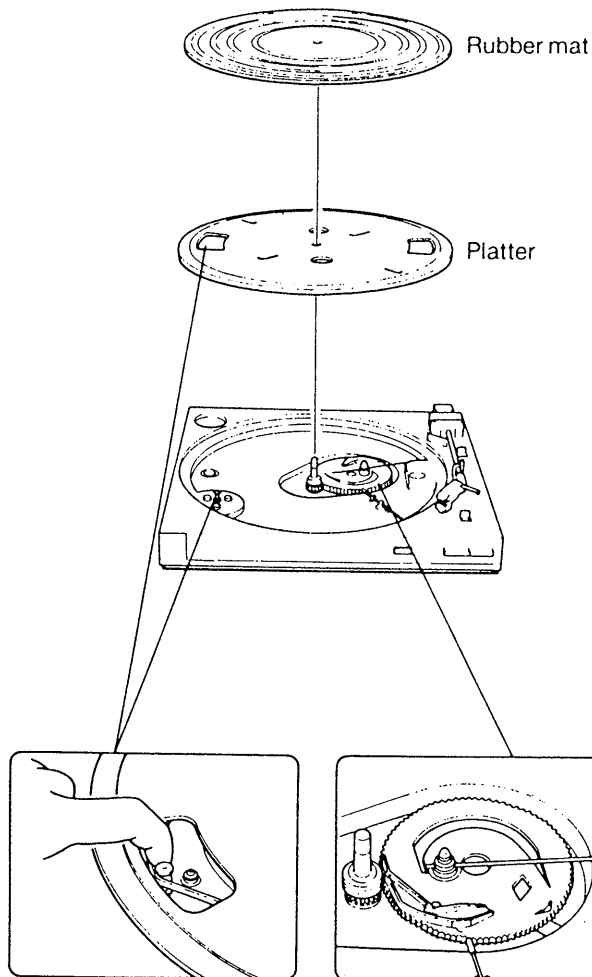

Hook the belt on the motor pulley.

If the belt is removed from the platter, replace it with the glossy side outward.

### Speed Adjustment

**Note:** Be sure to perform 45rpm adjustment before 33 rpm.

1. Place a stroboscope board on the turntable sheet.
2. Set the SPEED switch to 45.  
Press the START button.  
Adjust VR2 so that the stripped pattern of stroboscope board is stationary.
3. Set the SPEED switch to 33.  
Adjust VR1 in the same way.

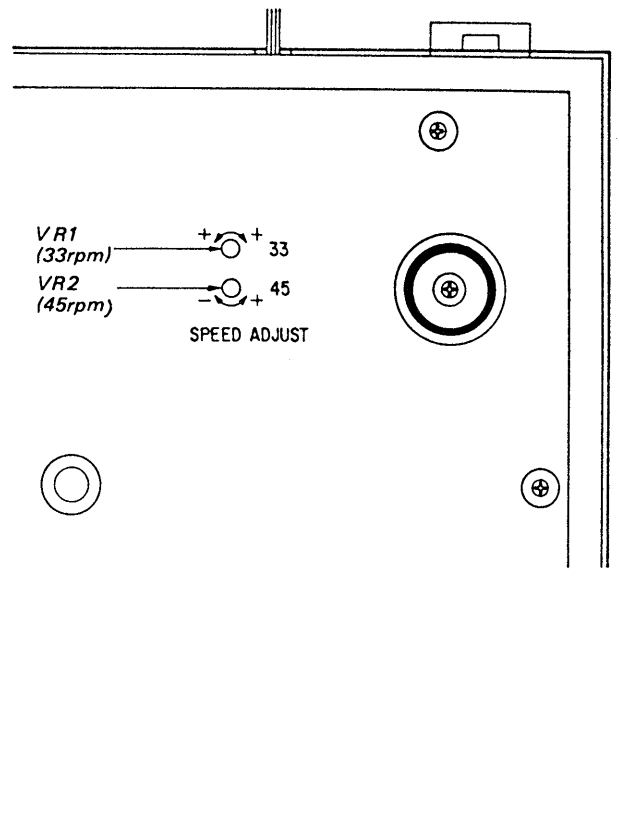

### Stylus Drop-point Adjustment

1. Place a test record (YFSC-16) on the turntable sheet.
2. Set the SPEED switch to 33.
3. Press the START button.
4. By using a screwdriver, turn the adjustment screw so that the stylus tip drops on the record at the 7-17 counts position.
5. Move the arm to return detecting groove and confirm that the auto-return operation is started normally.

**Note:** The proper adjustment for a 30cm record is also correct for a 17cm record.  
When turning adjustment screw, put the arm on the arm rest.

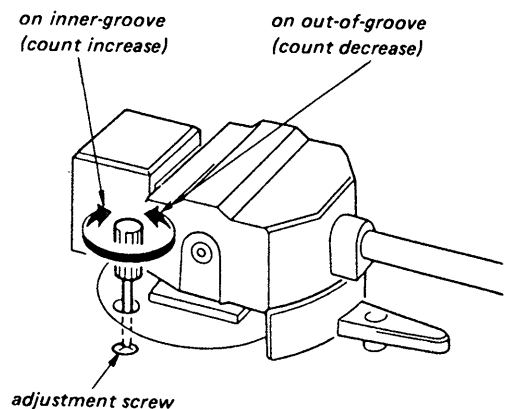

SCHMATIC DIAGRAM

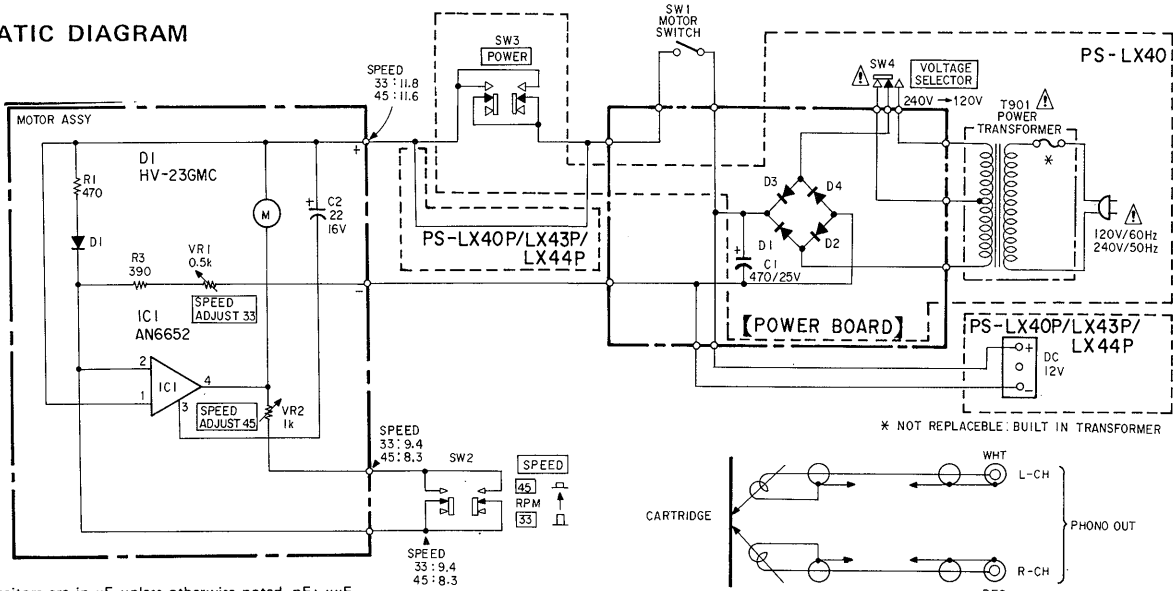

Note:

- All capacitors are in  $\mu F$  unless otherwise noted. pF:  $\mu F$  50WV or less are not indicated except for electrolytics and tantalums.
- All resistors are in  $\Omega$  and  $\frac{1}{4}W$  or less unless otherwise specified.
- Switches:

Ref. No.	Switch	Position
SW1	MOTOR	OFF
SW2	SPEED	33
SW3	POWER	OFF
SW4	VOLTAGE SELECTOR	240V

Note: The components identified by mark  $\Delta$  or dotted line with mark  $\Delta$  are critical for safety. Replace only with part number specified.

WIRING DIAGRAM

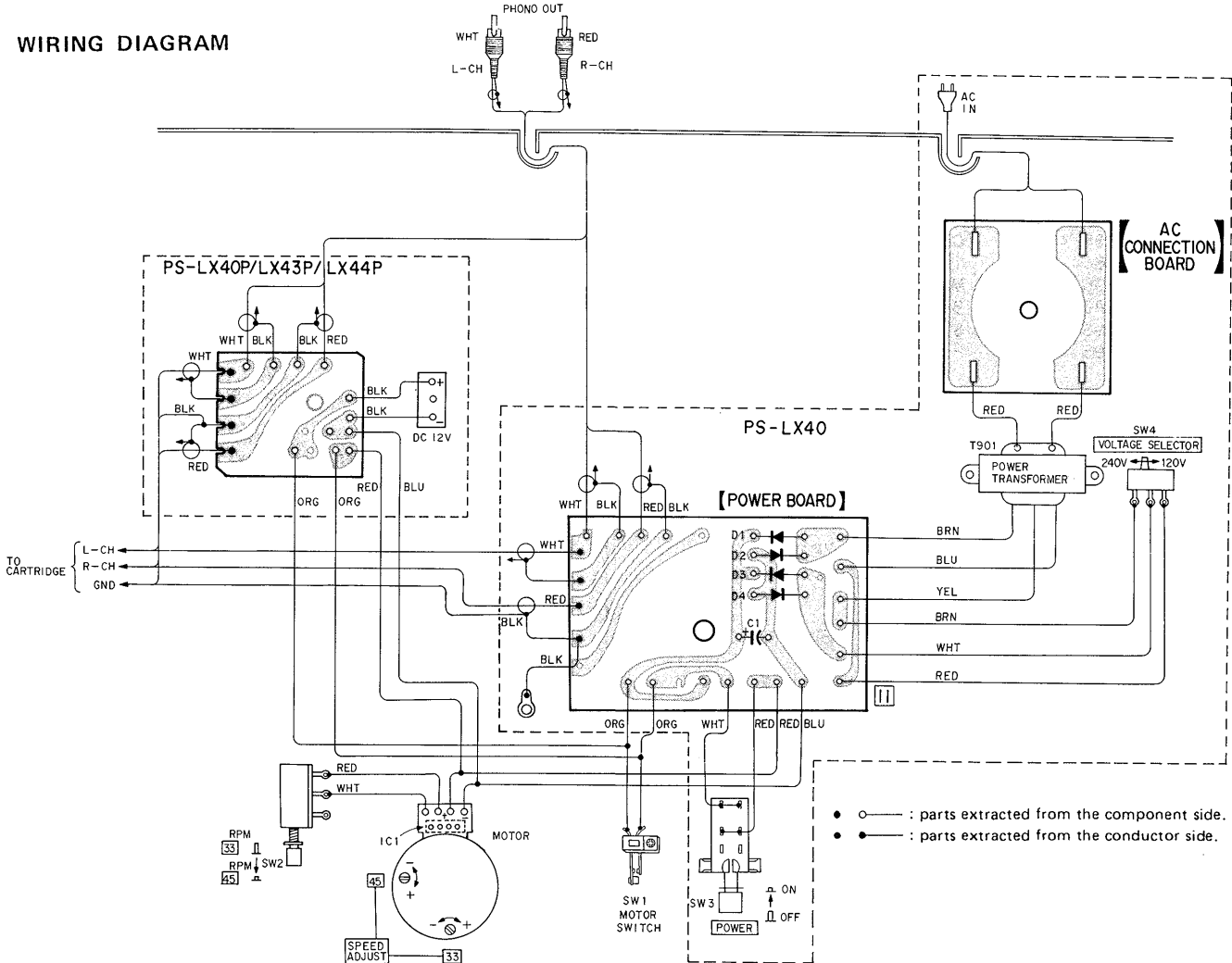



- ○ : parts extracted from the component side.
- ● : parts extracted from the conductor side.







**ELECTRICAL PARTS**

**NOTE:**

- Due to standardization, replacements in the parts list may be different from the parts specified in the diagrams or the components used on the set.
- Items marked “\*” are not stocked since they are seldom required for routine service. Some delay should be anticipated when ordering these items.
- If there are two or more same circuits in a set such as a stereophonic machine, only typical circuit parts may be indicated and capacitors and resistors in other same circuits may be omitted.

The components identified by mark  or dotted line with mark  are critical for safety. Replace only with part number specified.

<u>Ref. No.</u>	<u>Part No.</u>	<u>Description</u>
902	1-549-135-11	CARTRIDGE
903	- - -	(LX40)...PC BOARD, POWER
904	 1-555-795-00	(LX40:AEP, West Germany, Saudi Arabia) .....CORD, POWER, EULO PLUG
	 1-551-188-XX	(LX40:E)...CORD, POWER
905	1-555-116-11	CORD, CONNECTION
906	1-557-109-21	(LX40P/LX43P/LX44P)...CORD, CONNECTION (3 CORE)
C1	1-123-336-00	ELECT 470μF 25V
D1	8-719-200-02	(LX40)...DIODE 10E2
D2	8-719-200-02	(LX40)...DIODE 10E2
D3	8-719-200-02	(LX40)...DIODE 10E2
D4	8-719-200-02	(LX40)...DIODE 10E2
M1	A-4604-244-A	MOTOR ASSY
SW1	1-570-666-11	SWITCH, LEAF
SW2	1-571-089-11	SWITCH, PUSH (1 KEY) (SPEED)
SW3	1-571-560-11	(LX40)...SWITCH, PUSH (1 KEY) (POWER)
SW4	 1-571-088-11	(LX40)...SWITCH, SLIDE (VOLTAGE SELECTOR)
T901	 1-449-291-11	(LX40)...TRANSFORMER; POWER

ACCESSORY & PACKING MATERIAL

3-701-806-00	ADAPTOR, 45
3-750-345-11	(LX40)...MANUAL, INSTRUCTION (English, French, Spanish)
4-896-513-01	(LX40)...INDIVIDUAL CARTON
4-896-384-01	(EXCEPT LX40).....CUSHION(R)
4-896-385-01	(EXCEPT LX40).....CUSHION(L)